

**Ministry of the
Environment,
Conservation and Parks**
Eastern Region
Ottawa District Office
2430 Don Reid Drive, Suite 103
Ottawa ON K1H 1E1
Phone: 613.521.3450
or 800.860.2195
Fax: 613.521.5437

**Ministère de l'Environnement,
de la Protection de la nature
et des Parcs**
Région de l'Est
Bureau du district d'Ottawa
2430, promenade Don Reid unité 103
Ottawa (Ontario) K1H 1E1
Tél: 613 521-3450
ou 800 860-2195
Télé: 613 521-5437



January 18, 2024

Sent by Email: rpaquette@arnprior.ca

Robin Paquette – Chief Administrative Officer
The Corporation of the Town of Arnprior
105 Elgin Street
Arnprior ON, K7S 0A8

Attention: Robin,

Re: Arnprior DWS 2023-24 Inspection Report # 1-207755721

The enclosed report documents findings of the inspection that was performed at the Arnprior drinking water system on December 14, 2023.

One section of the report, namely “Non-compliance/Non-conformance Items”, if found, may cite due dates for the submission of information or plans to my attention.

Please note that Non-compliance Items are linked to incidents of non-compliance with regulatory requirements contained within an act, a regulation, or site-specific approvals, licenses, permits, orders, or instructions. Such violations may result in the issuance of mandatory abatement instruments which could include orders, tickets, penalties, or referrals to the ministry’s Environmental Enforcement and Compliance Office.

Non-conformance Items convey information that the owner or operating authority should consider implementing in order to advance efforts already in place to address such issues as emergency preparedness, the fulsome availability of information to consumers, and conformance with existing and emerging industry standards. Please note that items which appear as recommended actions do not, in themselves, constitute violations.

In order to measure individual inspection results, the ministry continues to adhere to an inspection compliance risk framework based on the principles of the Inspection, Investigation & Enforcement (II&E) Secretariat and advice of internal/external risk

experts. The Inspection Rating Record (IRR) provides the ministry, the system owner and the local Public Health Unit with a summarized quantitative measure of the drinking water system's annual inspection and regulated water quality testing performance. Please note, the IRR will be sent separately and prior to any public release (typically within 1 to 2 months of the completion of the inspection). IRR ratings are published in the ministry's Chief Drinking Water Inspector's Annual Report. If you have any questions or concerns regarding the rating, please contact Shannon Hamilton-Browne, Acting Water Compliance Supervisor, at 613-521-3450.

Section 19 of the Safe Drinking Water Act, 2002 (Standard of Care) cites a number of obligations of individuals who exercise decision-making authority over municipal drinking water systems. The ministry encourages individuals, particularly municipal councilors, to take steps to be well informed about the drinking water systems over which they have decision-making authority. These steps could include asking for a copy of this inspection report and a review of its findings.

Thank you for the assistance afforded to me during the conduct of the compliance assessment. Should you have any questions regarding the content of the enclosed report, please do not hesitate to contact me.

Yours truly,

A handwritten signature in cursive script, appearing to read "David Trombley".

David Trombley
Water Compliance Officer, Badge #1532
Ministry of the Environment, Conservation and Parks
Drinking Water and Environmental Compliance Division, Ottawa District Office
Cell: 613-876-1635

Enclosure

- ec: - Scott Matthews, Waterworks Supervisor, Town of Arnprior,
smatthews@arnprior.ca
- John Steckly, General Manager of Operations, Town of Arnprior,
jsteckly@arnprior.ca
- Randy McLaren, District Manager, Ministry of Natural Resources and Forestry,
randy.mclaren@ontario.ca
- David Tantalo, Manager, Healthy Environments, Renfrew County & District
Health Unit, dtantalo@rcdhu.com
- c: File SI-RE-AR-JA-540 (2023-24)



ARNPRIOR DRINKING WATER SYSTEM
71 JAMES ST, ARNPRIOR, ON, K7S 1E1
INSPECTION REPORT

System Number: 220000932
Entity: CORPORATION OF THE TOWN
OF ARNPRIOR
Inspection Start Date: December 14, 2023
Inspection End Date: December 21, 2023
Inspected By: David Trombley
Badge #: 1532



(signature)

NON-COMPLIANCE

This should not be construed as a confirmation of full compliance with all potential applicable legal requirements. These inspection findings are limited to the components and/or activities that were assessed, and the legislative framework(s) that were applied. It remains the responsibility of the owner to ensure compliance with all applicable legislative and regulatory requirements.

If you have any questions related to this inspection, please contact the signed Provincial Officer.

RECOMMENDATIONS

This should not be construed as a confirmation of full conformance with all potential applicable BMPs. These inspection findings are limited to the components and/or activities that were assessed, and the legislative framework(s) that were applied. It remains the responsibility of the owner to ensure compliance with all applicable legislative and regulatory requirements.

If you have any questions related to this inspection, please contact the signed Provincial Officer.

INSPECTION DETAILS

This section includes all questions that were assessed during the inspection.

Ministry Program: DRINKING WATER | **Regulated Activity:** DW Municipal Residential

Question ID	DWMR1001000	Question Type	Information
Legislative Requirement(s): Not Applicable			
Question: What was the scope of this inspection?			
Compliance Response(s)/Corrective Action(s)/Observation(s): <p>The primary focus of this inspection is to confirm compliance with Ministry of the Environment, Conservation and Parks (MECP) legislation as well as evaluating conformance with ministry drinking water policies and guidelines during the inspection period. The ministry utilizes a comprehensive, multi-barrier approach in the inspection of water systems that focuses on the source, treatment, and distribution components as well as management practices.</p> <p>This drinking water system is subject to the legislative requirements of the Safe Drinking Water Act, 2002 (SDWA) and regulations made therein, including Ontario Regulation 170/03, "Drinking Water Systems" (O. Reg. 170/03). This inspection has been conducted pursuant to Section 81 of the SDWA.</p> <p>This inspection report does not suggest that all applicable legislation and regulations were evaluated. It remains the responsibility of the owner to ensure compliance with all applicable legislative and regulatory requirements.</p> <p>The Arnprior drinking water system is owned and operated by the Town of Arnprior and is categorized as a Large Municipal Residential (LMR) drinking water system. A focused announced inspection of the Arnprior DWS began on December 14, 2023 and consisted of a physical inspection of the DWS components which included the low lift pumping station, water purification plant and elevated storage tower, interviews and operational data review. The inspection was attended by Ministry of the Environment, Conservation and Parks Water Compliance Officer David Trombley and Town of Arnprior staff Scott Matthews, Waterworks Supervisor and Andrew Hoogenboom, Operator.</p> <p>Additional review of documentation relevant to the inspection was conducted at MECP offices. This inspection covers the period of February 1, 2023 to December 14, 2023 and will be referred to as the Inspection Period in this report.</p>			

Question ID	DWMR1000000	Question Type	Information
Legislative Requirement(s): Not Applicable			
Question:			

Does this drinking water system provide primary disinfection?
Compliance Response(s)/Corrective Action(s)/Observation(s): This drinking water system provides for both primary and secondary disinfection and distribution of water.

Question ID	DWMR1012000	Question Type	Legislative
Legislative Requirement(s): SDWA 31 (1);			
Question: Does the owner have a harmful algal bloom monitoring plan in place that meets the requirements of the MDWL?			
Compliance Response(s)/Corrective Action(s)/Observation(s): The owner had a harmful algal bloom monitoring plan in place.			

Question ID	DWMR1014000	Question Type	Legislative
Legislative Requirement(s): SDWA 31 (1);			
Question: Is there sufficient monitoring of flow as required by the MDWL or DWWP issued under Part V of the SDWA?			
Compliance Response(s)/Corrective Action(s)/Observation(s): There was sufficient monitoring of flow as required by the Municipal Drinking Water Licence or Drinking Water Works Permit issued under Part V of the SDWA.			

Question ID	DWMR1016000	Question Type	Legislative
Legislative Requirement(s): SDWA 31 (1);			
Question: Is the owner in compliance with the conditions associated with maximum flow rate or the rated capacity conditions in the MDWL issued under Part V of the SDWA?			
Compliance Response(s)/Corrective Action(s)/Observation(s): The owner was in compliance with the conditions associated with maximum flow rate or the rated capacity conditions in the Municipal Drinking Water Licence issued under Part V of the SDWA. The rated capacity of the drinking water system cited in the Municipal Drinking Water Licence (MDWL) is 10,340 m ³ /day of treated water to the distribution system.			

The recorded maximum daily flow from the treatment system to the distribution system during the inspection period was 5,129 m3 which occurred on June 4, 2023.

Question ID	DWMR1018000	Question Type	Legislative
Legislative Requirement(s): SDWA 31 (1);			
Question: Has the owner ensured that all equipment is installed in accordance with Schedule A and Schedule C of the Drinking Water Works Permit?			
Compliance Response(s)/Corrective Action(s)/Observation(s): The owner had ensured that all equipment was installed in accordance with Schedule A and Schedule C of the Drinking Water Works Permit.			

Question ID	DWMR1020000	Question Type	Legislative
Legislative Requirement(s): SDWA 31 (1);			
Question: Is the owner/operating authority able to demonstrate that, when required during the inspection period, Form 1 documents were prepared in accordance with their Drinking Water Works Permit?			
Compliance Response(s)/Corrective Action(s)/Observation(s): The owner/operating authority was in compliance with the requirement to prepare Form 1 documents as required by their Drinking Water Works Permit during the inspection period. During the inspection period, form 1 documents were prepared for the installation of water mains on Corb Stewart Court and Baskin Road.			

Question ID	DWMR1021000	Question Type	Legislative
Legislative Requirement(s): SDWA 31 (1);			
Question: Is the owner/operating authority able to demonstrate that, when required during the inspection period, Form 2 documents were prepared in accordance with their Drinking Water Works Permit?			
Compliance Response(s)/Corrective Action(s)/Observation(s): The owner/operating authority was in compliance with the requirement to prepare Form 2 documents as required by their Drinking Water Works Permit during the inspection period. During the inspection period, a form 2 document was prepared for the replacement of the coagulant pump.			

Question ID	DWWMR1025000	Question Type	Legislative
Legislative Requirement(s): SDWA 31 (1);			
Question: Were all parts of the drinking water system that came in contact with drinking water (added, modified, replaced or extended) disinfected in accordance with a procedure listed in Schedule B of the Drinking Water Works Permit?			
Compliance Response(s)/Corrective Action(s)/Observation(s): All parts of the drinking water system were disinfected in accordance with a procedure listed in Schedule B of the Drinking Water Works Permit.			

Question ID	DWWMR1023000	Question Type	Legislative
Legislative Requirement(s): SDWA O. Reg. 170/03 1-2 (2);			
Question: Do records indicate that the treatment equipment was operated in a manner that achieved the design capabilities required under Ontario Regulation 170/03 or a DWWP and/or MDWL issued under Part V of the SDWA at all times that water was being supplied to consumers?			
Compliance Response(s)/Corrective Action(s)/Observation(s): Records indicated that the treatment equipment was operated in a manner that achieved the design capabilities required under O. Reg. 170/03 or a Drinking Water Works Permit and/or Municipal Drinking Water Licence issued under Part V of the SDWA at all times that water was being supplied to consumers. A review of daily process records indicates that all treatment processes were in use at all times water was being directed to the users of the drinking water system. Records also indicate that the combined chlorine residual measured in the distribution system was greater than 0.25 mg/L at all times during the inspection period.			

Question ID	DWWMR1026000	Question Type	Legislative
Legislative Requirement(s): SDWA O. Reg. 170/03 1-6 (1);			
Question: If primary disinfection equipment that does not use chlorination or chloramination is provided, is the equipment equipped with alarms or shut-off mechanisms that satisfy the standards described in Section 1-6 (1) of Schedule 1 of Ontario Regulation 170/03?			
Compliance Response(s)/Corrective Action(s)/Observation(s): The primary disinfection equipment was equipped with alarms or shut-off mechanisms that satisfied the standards described in Section 1-6 (1) of Schedule 1 of O. Reg. 170/03.			

The Arnprior DWS source is the Madawaska River.

Where chlorination is used for primary disinfection, the 2 log removal credit for *Cryptosporidium* oocysts is considered to be attributed to the filtration process as chlorine at reasonable doses and contact times is ineffective in inactivating *Cryptosporidium* oocysts.

All of the primary disinfection processes at the Arnprior drinking water system's treatment plant including the filtration processes are equipped with automatic shut-off mechanisms and/or alarms.

Question ID	DWMR1024000	Question Type	Legislative
Legislative Requirement(s): SDWA O. Reg. 170/03 1-2 (2);			
Question: Do records confirm that the water treatment equipment which provides chlorination or chloramination for secondary disinfection purposes was operated as required?			
Compliance Response(s)/Corrective Action(s)/Observation(s): Records confirmed that the water treatment equipment which provides chlorination or chloramination for secondary disinfection purposes was operated so that at all times and all locations in the distribution system the chlorine residual was never less than 0.05 mg/l free or 0.25 mg/l combined. Secondary disinfection records indicate that the minimum combined chlorine residual recorded during the inspection period was 0.87 mg/L.			

Question ID	DWMR1033000	Question Type	Legislative
Legislative Requirement(s): SDWA O. Reg. 170/03 7-2 (3); SDWA O. Reg. 170/03 7-2 (4);			
Question: Is the secondary disinfectant residual measured as required for the large municipal residential distribution system?			
Compliance Response(s)/Corrective Action(s)/Observation(s): The secondary disinfectant residual was measured as required for the large municipal residential distribution system. Secondary disinfection residuals are measured by continuous measuring equipment located at the municipal wastewater treatment facility.			

Question ID	DWMR1030000	Question Type	Legislative
Legislative Requirement(s): SDWA O. Reg. 170/03 7-2 (1); SDWA O. Reg. 170/03 7-2 (2);			

Question:

Is primary disinfection chlorine monitoring being conducted at a location approved by MDWL and/or DWWP issued under Part V of the SDWA, or at/near a location where the intended CT has just been achieved?

Compliance Response(s)/Corrective Action(s)/Observation(s):

Primary disinfection chlorine monitoring was conducted at a location approved by Municipal Drinking Water Licence and/or Drinking Water Works Permit issued under Part V of the SDWA, or at/near a location where the intended CT has just been achieved.

Question ID	DWMMR1032000	Question Type	Legislative
Legislative Requirement(s): SDWA O. Reg. 170/03 7-3 (2);			
Question: If the drinking water system obtains water from a surface water source and provides filtration, is continuous monitoring of each filter effluent line being performed for turbidity?			
Compliance Response(s)/Corrective Action(s)/Observation(s): Continuous monitoring of each filter effluent line was being performed for turbidity.			

Question ID	DWMMR1035000	Question Type	Legislative
Legislative Requirement(s): SDWA O. Reg. 170/03 6-5 (1)1-4; SDWA O. Reg. 170/03 6-5 (1)5-10;			
Question: Are operators examining continuous monitoring test results and are they examining the results within 72 hours of the test?			
Compliance Response(s)/Corrective Action(s)/Observation(s): Operators were examining continuous monitoring test results and they were examining the results within 72 hours of the test. During the inspection period, continuous monitoring test results were reviewed daily. This activity was recorded and signed off by operators on the facilities daily report.			

Question ID	DWMMR1038000	Question Type	Legislative
Legislative Requirement(s): SDWA O. Reg. 170/03 6-5 (1)1-4;			
Question: Is continuous monitoring equipment that is being utilized to fulfill O. Reg. 170/03 requirements performing tests for the parameters with at least the minimum frequency specified in the Table in Schedule 6 of O. Reg. 170/03 and recording data with the prescribed format?			
Compliance Response(s)/Corrective Action(s)/Observation(s):			

Continuous monitoring equipment that was being utilized to fulfill O. Reg. 170/03 requirements was performing tests for the parameters with at least the minimum frequency specified in the Table in Schedule 6 of O. Reg. 170/03 and recording data with the prescribed format.

Question ID	DWMR1037000	Question Type	Legislative
Legislative Requirement(s): SDWA O. Reg. 170/03 6-5 (1)1-4; SDWA O. Reg. 170/03 6-5 (1)5-10; SDWA O. Reg. 170/03 6-5 (1.1);			
Question: Are all continuous monitoring equipment utilized for sampling and testing required by O. Reg. 170/03, or MDWL or DWWP or order, equipped with alarms or shut-off mechanisms that satisfy the standards described in Schedule 6?			
Compliance Response(s)/Corrective Action(s)/Observation(s): All continuous monitoring equipment utilized for sampling and testing required by O. Reg. 170/03, or Municipal Drinking Water Licence or Drinking Water Works Permit or order, were equipped with alarms or shut-off mechanisms that satisfy the standards described in Schedule 6.			

Question ID	DWMR1040000	Question Type	Legislative
Legislative Requirement(s): SDWA O. Reg. 170/03 6-5 (1)1-4; SDWA O. Reg. 170/03 6-5 (1)5-10;			
Question: Are all continuous analysers calibrated, maintained, and operated, in accordance with the manufacturer's instructions or the regulation?			
Compliance Response(s)/Corrective Action(s)/Observation(s): All continuous analysers were calibrated, maintained, and operated, in accordance with the manufacturer's instructions or the regulation.			

Question ID	DWMR1108000	Question Type	Legislative
Legislative Requirement(s): SDWA O. Reg. 170/03 6-5 (1)1-4; SDWA O. Reg. 170/03 6-5 (1)5-10; SDWA O. Reg. 170/03 6-5 (1.1);			
Question: Where continuous monitoring equipment used for the monitoring of free chlorine residual, total chlorine residual, combined chlorine residual or turbidity, required by O. Reg. 170/03, an Order, MDWL, or DWWP issued under Part V, SDWA, has triggered an alarm or an automatic shut-off, did a qualified person respond in a timely manner and take appropriate actions?			
Compliance Response(s)/Corrective Action(s)/Observation(s):			

Where required continuous monitoring equipment used for the monitoring of chlorine residual and/or turbidity triggered an alarm or an automatic shut-off, a qualified person responded in a timely manner and took appropriate actions.

A review of operator log books indicated that during the inspection period, operators responded to disinfection parameter alarms in a timely manner and took appropriate actions in response to the alarm conditions.

Question ID	DWMMR1039000	Question Type	Legislative
Legislative Requirement(s): SDWA O. Reg. 170/03 1-6 (3);			
Question: If primary disinfection equipment that does not use chlorination or chloramination is provided, has the owner and operating authority ensured that the equipment has a recording device that continuously records the performance of the disinfection equipment?			
Compliance Response(s)/Corrective Action(s)/Observation(s): The owner and operating authority ensured that the primary disinfection equipment had a recording device that continuously recorded the performance of the disinfection equipment. Monitoring of filter effluent turbidity by continuous monitoring equipment is conducted by SCADA which records the filter performance criteria.			

Question ID	DWMMR1099000	Question Type	Information
Legislative Requirement(s): Not Applicable			
Question: Do records show that all water sample results taken during the inspection review period did not exceed the values of tables 1, 2 and 3 of the Ontario Drinking Water Quality Standards (O. Reg. 169/03)?			
Compliance Response(s)/Corrective Action(s)/Observation(s): Records showed that all water sample results taken during the inspection review period did not exceed the values of tables 1, 2 and 3 of the Ontario Drinking Water Quality Standards (O. Reg. 169/03).			

Question ID	DWMMR1081000	Question Type	Legislative
Legislative Requirement(s): SDWA O. Reg. 170/03 10-2 (1); SDWA O. Reg. 170/03 10-2 (2); SDWA O. Reg. 170/03 10-2 (3);			
Question: For LMR systems, are all microbiological water quality monitoring requirements for distribution samples being met?			

Compliance Response(s)/Corrective Action(s)/Observation(s):

All microbiological water quality monitoring requirements prescribed by legislation for distribution samples in a large municipal residential system were being met.

O. Reg. 170/03 Schedule 10:

10-2. (1) The owner of a drinking water system and the operating authority for the system shall ensure that,

(a) if the system serves 100,000 people or less, at least eight distribution samples, plus one additional distribution sample for every 1,000 people served by the system, are taken every month, with at least one of the samples being taken in each week; and

(b) if the system serves more than 100,000 people, at least 100 distribution samples, plus one additional distribution sample for every 10,000 people served by the system, are taken every month, with at least three of the samples being taken in each week.

(2) The owner of the drinking water system and the operating authority for the system shall ensure that each of the samples taken under subsection (1) is tested for,

(a) Escherichia coli; and

(b) total coliforms.

(3) The owner of the drinking water system and the operating authority for the system shall ensure that at least 25 per cent of the samples required to be taken under subsection (1) are tested for general bacteria population expressed as colony counts on a heterotrophic plate count.

According to the Arnprior drinking water system information provided, the system serves a population of approximately 8,795.

Records indicate that during the inspection period typically six (6) distribution samples were collected weekly, this number exceeds the minimum number of samples required by the regulations. All samples are tested for Escherichia coli, total coliforms and greater than 25% of these samples were tested for general bacteria population expressed as colony counts on a heterotrophic plate count.

Question ID	DWMR1083000	Question Type	Legislative
<p>Legislative Requirement(s): SDWA O. Reg. 170/03 10-3;</p>			
<p>Question: For LMR systems, are all microbiological water quality monitoring requirements for treated samples being met?</p>			
<p>Compliance Response(s)/Corrective Action(s)/Observation(s): All microbiological water quality monitoring requirements prescribed by legislation for treated samples were being met.</p>			

O. Reg. 170/03 Schedule 10:

10-3. The owner of a drinking water system and the operating authority for the system shall ensure that a water sample is taken at least once every week and tested for,

- (a) Escherichia coli;
- (b) total coliforms; and
- (c) general bacteria population expressed as colony counts on a heterotrophic plate count.

Records indicate that during the inspection period samples were collected weekly from treated water and tested for Escherichia coli, total coliforms and general bacteria population expressed as colony counts on a heterotrophic plate count.

Question ID	DWMR1096000	Question Type	Legislative
Legislative Requirement(s): SDWA O. Reg. 170/03 6-3 (1);			
Question: Do records confirm that chlorine residual tests are being conducted at the same time and at the same location that microbiological samples are obtained?			
Compliance Response(s)/Corrective Action(s)/Observation(s): Records confirmed that chlorine residual tests were being conducted at the same time and at the same location that microbiological samples were obtained. It was reported that during the inspection period, chlorine residual tests were conducted at the same time and location as microbiological samples were obtained and it was observed that the results of the tests were recorded on the laboratory chain of custody forms.			

Question ID	DWMR1084000	Question Type	Legislative
Legislative Requirement(s): SDWA O. Reg. 170/03 13-2;			
Question: Are all inorganic water quality monitoring requirements prescribed by legislation conducted within the required frequency?			
Compliance Response(s)/Corrective Action(s)/Observation(s): All inorganic water quality monitoring requirements prescribed by legislation were conducted within the required frequency. O. Reg. 170/03 Schedule 13: 13-2. (1) The owner of a large municipal residential system and the operating authority for the system shall ensure that, (a) at least one water sample is taken every 12 months, if the system obtains water from a raw water supply that is surface water; or			

(b) at least one water sample is taken every 36 months, if the system obtains water from a raw water supply that is ground water.

(2) The owner of a large municipal residential system and the operating authority for the system shall ensure that each of the samples taken under subsection (1) is tested for every parameter set out in Schedule 23.

The Arnprior DWS obtains its raw water from the Madawaska River (surface water).

Sampling records indicate that the DWS sampled and tested treated water for every parameter set out in Schedule 23 previously on January 18, 2023. This sampling was performed within the required frequency.

Sampling and testing for every parameter set out in Schedule 23 is required next on January 18, 2024 (+/-) 30 days

Question ID	DWMR1085000	Question Type	Legislative
<p>Legislative Requirement(s): SDWA O. Reg. 170/03 13-4 (1); SDWA O. Reg. 170/03 13-4 (2); SDWA O. Reg. 170/03 13-4 (3);</p>			
<p>Question: Are all organic water quality monitoring requirements prescribed by legislation conducted within the required frequency?</p>			
<p>Compliance Response(s)/Corrective Action(s)/Observation(s): All organic water quality monitoring requirements prescribed by legislation were conducted within the required frequency.</p> <p>O. Reg. 170/03 Schedule 13:</p> <p>13-4. (1) The owner of a large municipal residential system and the operating authority for the system shall ensure that,</p> <p>(a) at least one water sample is taken every 12 months, if the system obtains water from a raw water supply that is surface water; or</p> <p>(b) at least one water sample is taken every 36 months, if the system obtains water from a raw water supply that is ground water.</p> <p>(2) The owner of a large municipal residential system and the operating authority for the system shall ensure that each of the samples taken under subsection (1) is tested for every parameter set out in Schedule 24.</p> <p>The Arnprior DWS obtains its raw water from the Madawaska River (surface water).</p> <p>Sampling records indicate that the DWS sampled and tested treated water for every parameter set out in Schedule 24 previously on January 17, 2023. This sampling was performed within the</p>			

required frequency.

Sampling and testing for every parameter set out in Schedule 24 is required next on January 17, 2024 (+/-) 30 days

Question ID	DWMR1086000	Question Type	Legislative
Legislative Requirement(s):			
SDWA O. Reg. 170/03 13-6.1 (1); SDWA O. Reg. 170/03 13-6.1 (2); SDWA O. Reg. 170/03 13-6.1 (3); SDWA O. Reg. 170/03 13-6.1 (4); SDWA O. Reg. 170/03 13-6.1 (5); SDWA O. Reg. 170/03 13-6.1 (6);			
Question:			
Are all haloacetic acid water quality monitoring requirements prescribed by legislation conducted within the required frequency and at the required location?			
Compliance Response(s)/Corrective Action(s)/Observation(s):			
All haloacetic acid water quality monitoring requirements prescribed by legislation were conducted within the required frequency and at the required location.			
O. Reg. 170/03 Schedule 13:			
13-6.1 (1) The owner of a drinking water system that provides chlorination or chloramination and the operating authority for the system shall ensure that at least one distribution sample is taken in each calendar quarter, from a point in the drinking water system's distribution system, or plumbing that is connected to the drinking water system, that is likely to have an elevated potential for the formation of haloacetic acids.			
(2) The owner of the drinking water system and the operating authority for the system shall ensure that each of the samples taken under subsection (1) is tested for haloacetic acids.			
O. Reg. 170/03 Schedule 6:			
6-1.1 (4) If this Regulation or an approval, municipal drinking water licence or order, including an OWRA approval or OWRA order, requires at least one water sample to be taken every three months or in each calendar quarter and tested for a parameter, the owner of the drinking water system and the operating authority for the system shall ensure that at least one sample that is taken during a three-month period or calendar quarter for the purpose of being tested for that parameter is taken at least 60 days, and not more than 120 days, after a sample was taken for that purpose in the previous three-month period or calendar quarter.			
Sampling records indicate that during the inspection period samples were collected from the distribution system quarterly during the months of April, July and October and tested for haloacetic acids. This sampling was conducted within the required frequency.			

Question ID	DWMR1087000	Question Type	Legislative
Legislative Requirement(s):			

SDWA | O. Reg. 170/03 | 13-6 | (1); SDWA | O. Reg. 170/03 | 13-6 | (2); SDWA | O. Reg. 170/03 | 13-6 | (3); SDWA | O. Reg. 170/03 | 13-6 | (4); SDWA | O. Reg. 170/03 | 13-6 | (5); SDWA | O. Reg. 170/03 | 13-6 | (6);

Question:

Have all trihalomethane water quality monitoring requirements prescribed by legislation been conducted within the required frequency and at the required location?

Compliance Response(s)/Corrective Action(s)/Observation(s):

All trihalomethane water quality monitoring requirements prescribed by legislation were conducted within the required frequency and at the required location.

O. Reg. 170/03 Schedule 13:

13-6. (1) The owner of a drinking water system that provides chlorination or chloramination and the operating authority for the system shall ensure that at least one distribution sample is taken in each calendar quarter, from a point in the drinking water system's distribution system, or plumbing that is connected to the drinking water system, that is likely to have an elevated potential for the formation of trihalomethanes.

(2) The owner of the drinking water system and the operating authority for the system shall ensure that each of the samples taken under subsection (1) is tested for trihalomethanes.

Sampling records indicate that during the inspection period samples were collected from the distribution system quarterly during the months of April, July and October and tested for trihalomethanes. This sampling was conducted within the required frequency.

Question ID	DWMR1088000	Question Type	Legislative
<p>Legislative Requirement(s): SDWA O. Reg. 170/03 13-7;</p>			
<p>Question: Are all nitrate/nitrite water quality monitoring requirements prescribed by legislation conducted within the required frequency for the DWS?</p>			
<p>Compliance Response(s)/Corrective Action(s)/Observation(s): All nitrate/nitrite water quality monitoring requirements prescribed by legislation were conducted within the required frequency.</p> <p>O. Reg. 170/03 Schedule 13:</p> <p>13-7. The owner of a drinking water system and the operating authority for the system shall ensure that at least one water sample is taken every three months and tested for nitrate and nitrite.</p> <p>Sampling records indicate that during the inspection period samples were collected from treated water quarterly during the months of April, July and October and tested for nitrate and nitrite. This sampling was conducted within the required frequency</p>			

Question ID	DWMR1089000	Question Type	Legislative
Legislative Requirement(s): SDWA O. Reg. 170/03 13-8;			
Question: Are all sodium water quality monitoring requirements prescribed by legislation conducted within the required frequency?			
Compliance Response(s)/Corrective Action(s)/Observation(s): All sodium water quality monitoring requirements prescribed by legislation were conducted within the required frequency. O. Reg. 170/03 Schedule 13: 13-8. The owner of a drinking water system and the operating authority for the system shall ensure that at least one water sample is taken every 60 months and tested for sodium. Sampling records indicate that treated water samples are collected annually and sampled for sodium. This sampling frequency exceeds the minimum frequency required by the regulation.			

Question ID	DWMR1091000	Question Type	Legislative
Legislative Requirement(s): SDWA O. Reg. 170/03 7-4;			
Question: Where fluoridation is practiced, are the required daily samples being taken at the end of the fluoridation process?			
Compliance Response(s)/Corrective Action(s)/Observation(s): The required daily samples were being taken at the end of the fluoridation process. Fluoride concentration is measured by continuous monitoring equipment at the end of clear well #1 which represents the end of the fluoridation process.			

Question ID	DWMR1094000	Question Type	Legislative
Legislative Requirement(s): SDWA 31 (1);			
Question: Are all water quality monitoring requirements imposed by the MDWL and DWWP being met?			
Compliance Response(s)/Corrective Action(s)/Observation(s): All water quality monitoring requirements imposed by the MDWL or DWWP issued under Part V of the SDWA were being met. Tables 5 and 6 of the Municipal Drinking Water Licence (MDWL) list five (5) additional			

parameters that require quarterly sampling, testing and monitoring.

Sampling records indicate that during the inspection period samples were collected and tested quarterly in the months of April, July and October for NDMA, Benzo-pyrene, Total Organic Carbon, Dissolved Organic Carbon and Colour as required by the MDWL.

Question ID	DWMR1060000	Question Type	Legislative
Legislative Requirement(s): SDWA 31 (1);			
Question: Do the operations and maintenance manuals meet the requirements of the DWWP and MDWL issued under Part V of the SDWA?			
Compliance Response(s)/Corrective Action(s)/Observation(s): The operations and maintenance manuals met the requirements of the Drinking Water Works Permit and Municipal Drinking Water Licence issued under Part V of the SDWA.			

Question ID	DWMR1062000	Question Type	Legislative
Legislative Requirement(s): SDWA O. Reg. 170/03 7-5;			
Question: Do records or other record keeping mechanisms confirm that operational testing not performed by continuous monitoring equipment is being done by a certified operator, water quality analyst, or person who meets the requirements of O. Reg. 170/03 7-5?			
Compliance Response(s)/Corrective Action(s)/Observation(s): Records or other record keeping mechanisms confirmed that operational testing not performed by continuous monitoring equipment was being done by a certified operator, water quality analyst, or person who suffices the requirements of O. Reg. 170/03 7-5.			

Question ID	DWMR1071000	Question Type	BMP
Legislative Requirement(s): Not Applicable			
Question: Has the owner provided security measures to protect components of the drinking water system?			
Compliance Response(s)/Corrective Action(s)/Observation(s): The owner had provided security measures to protect components of the drinking water system. Security measures to protect components of the drinking water system include perimeter fencing with locked gates, building security with intrusion alarms and security cameras.			

Question ID	DWMMR1073000	Question Type	Legislative
Legislative Requirement(s): SDWA O. Reg. 128/04 23 (1);			
Question: Has the overall responsible operator been designated for all subsystems which comprise the drinking water system?			
Compliance Response(s)/Corrective Action(s)/Observation(s): The overall responsible operator had been designated for each subsystem.			

Question ID	DWMMR1074000	Question Type	Legislative
Legislative Requirement(s): SDWA O. Reg. 128/04 25 (1);			
Question: Have operators-in-charge been designated for all subsystems which comprise the drinking water system?			
Compliance Response(s)/Corrective Action(s)/Observation(s): Operators-in-charge had been designated for all subsystems which comprise the drinking water system.			

Question ID	DWMMR1075000	Question Type	Legislative
Legislative Requirement(s): SDWA O. Reg. 128/04 22;			
Question: Do all operators possess the required certification?			
Compliance Response(s)/Corrective Action(s)/Observation(s): All operators possessed the required certification.			

Question ID	DWMMR1076000	Question Type	Legislative
Legislative Requirement(s): SDWA O. Reg. 170/03 1-2 (2);			
Question: Do only certified operators make adjustments to the treatment equipment?			
Compliance Response(s)/Corrective Action(s)/Observation(s): Only certified operators made adjustments to the treatment equipment.			

APPENDIX A

**DRINKING WATER LICENCE AND
WORKS PERMIT**



MUNICIPAL DRINKING WATER LICENCE

Licence Number: 170-101

Issue Number: 7

Pursuant to the *Safe Drinking Water Act*, 2002, S.O. 2002, c. 32, and the regulations made thereunder and subject to the limitations thereof, I hereby issue this municipal drinking water licence under Part V of the *Safe Drinking Water Act*, 2002, S.O. 2002, c. 32 to:

Arnprior, The Corporation of the Town of

**105 Elgin St
Arnprior, ON K7S 0A8**

For the following municipal residential drinking water system:

Arnprior Drinking Water System

This municipal drinking water licence includes the following:

Schedule	Description
Schedule A	Drinking Water System Information
Schedule B	General Conditions
Schedule C	System-Specific Conditions
Schedule D	Conditions for Relief from Regulatory Requirements
Schedule E	Pathogen Log Removal/Inactivation Credits

Upon the effective date of this drinking water licence # 170-101, all previously issued versions of licence # 170-101 are revoked and replaced by this licence.

DATED at TORONTO this 31st day of March, 2021

Signature

Aziz Ahmed, P.Eng.
Director
Part V, *Safe Drinking Water Act*, 2002

Schedule A: Drinking Water System Information

System Owner	Arnprior, The Corporation of the Town of
Licence Number	170-101
Drinking Water System Name	Arnprior Drinking Water System
Licence Effective Date	March 31, 2021

1.0 Licence Information

Licence Issue Date	March 31, 2021
Licence Effective Date	March 31, 2021
Licence Expiry Date	March 31, 2026
Application for Licence Renewal Date	September 30, 2025

2.0 Incorporated Documents

The following documents are applicable to the above drinking water system and form part of this licence:

2.1 Drinking Water Works Permit

Drinking Water System Name	Permit Number	Issue Date
Arnprior Drinking Water System	170-201	March 31, 2021

2.2 Permits to Take Water

Water Taking Location	Permit Number	Issue Date
Madawaska River	4143-8ZDLMJ	October 23, 2012

3.0 Financial Plans

The Financial Plan Number for the Financial Plan required to be developed for this drinking water system in accordance with O. Reg. 453/07 shall be:	170-301
Alternately, if one Financial Plan is developed for all drinking water systems owned by the owner, the Financial Plan Number shall be:	170-301A

4.0 Accredited Operating Authority

Drinking Water System or Operational Subsystems	Accredited Operating Authority	Operational Plan No.	Operating Authority No.
Walter E. Prentice Water Filtration Plant and Distribution System	Arnprior, The Corporation Of The Town Of	170-401	170-OA1

Schedule B: General Conditions

System Owner	Arnprior, The Corporation of the Town of
Licence Number	170-101
Drinking Water System Name	Arnprior Drinking Water System
Licence Effective Date	March 31, 2021

1.0 Definitions

1.1 Words and phrases not defined in this licence and the associated drinking water works permit shall be given the same meaning as those set out in the SDWA and any regulations made in accordance with that act, unless the context requires otherwise.

1.2 In this licence and the associated drinking water works permit:

“**adverse effect**”, “**contaminant**” and “**natural environment**” shall have the same meanings as in the EPA;

“**alteration**” may include the following in respect of this drinking water system:

- (a) An addition to the system,
- (b) A modification of the system,
- (c) A replacement of part of the system, and
- (d) An extension of the system;

“**compound of concern**” means a contaminant described in paragraph 4 subsection 26 (1) of O. Reg. 419/05, namely, a contaminant that is discharged to the air from a component of the drinking water system in an amount that is not negligible;

“**CT**” means the CT Disinfection Concept, as described in subsection 3.1.1 of the Ministry’s Procedure for Disinfection of Drinking Water in Ontario, dated July 29 2016.

“**Director**” means a Director appointed pursuant to section 6 of the SDWA for the purposes of Part V of the SDWA;

“**drinking water works permit**” means the drinking water works permit for the drinking water system, as identified in Schedule A of this licence and as amended from time to time;

“**emission summary table**” means a table described in paragraph 14 of subsection 26 (1) of O. Reg. 419/05;

“**EPA**” means the *Environmental Protection Act*, R.S.O. 1990, c. E.19;

“**financial plan**” means the financial plan required by O. Reg. 453/07;

“**Harmful Algal Bloom (HAB)**” means an overgrowth of aquatic algal bacteria that produce or have the potential to produce toxins in the surrounding water, when the algal

cells are damaged or die. Such bacteria are harmful to people and animals and include microcystins produced by cyanobacterial blooms.

“**licence**” means this municipal drinking water licence for the municipal drinking water system identified in Schedule A of this licence;

“**Ministry**” means the Ontario Ministry of the Environment, Conservation and Parks;

“**operational plan**” means an operational plan developed in accordance with the Director’s Directions – Minimum Requirements for Operational Plans made under the authority of subsection 15(1) of the SDWA;

“**owner**” means the owner of the drinking water system as identified in Schedule A of this licence;

“**OWRA**” means the *Ontario Water Resources Act*, R.S.O. 1990, c. 0.40;

“**permit to take water**” means the permit to take water that is associated with the taking of water for purposes of the operation of the drinking water system, as identified in Schedule A of this licence and as amended from time to time;

“**point of impingement**” has the same meaning as in section 2 of O. Reg. 419/05 under the EPA;

“**point of impingement limit**” means the appropriate standard from Schedule 2 or 3 of O. Reg. 419/05 under the EPA and if a standard is not provided for a compound of concern, the concentration set out for the compound of concern in the document titled “Air Contaminants Benchmarks (ACB) List: Standards, guidelines and screening levels for assessing point of impingement concentrations of air contaminants”, as amended from time to time and published by the Ministry and available on a government of Ontario website;

“**licensed engineering practitioner**” means a person who holds a licence, limited licence or temporary licence under the Professional Engineers Act;

“**provincial officer**” means a provincial officer designated pursuant to section 8 of the SDWA;

“**publication NPC-300**” means the Ministry publication titled “Environmental Noise Guideline: Stationary and Transportation Sources – Approval and Planning” dated August 2013, as amended;

“**SCADA system**” means a supervisory control and data acquisition system used for process monitoring, automation, recording and/or reporting within the drinking water system;

“**SDWA**” means the *Safe Drinking Water Act*, 2002, S.O. 2002, c. 32;

“**sensitive receptor**” means any location where routine or normal activities occurring at reasonably expected times would experience adverse effect(s) from a discharge to air from an emergency generator that is a component of the drinking water system, including one or a combination of:

- (a) private residences or public facilities where people sleep (e.g.: single and multi-unit dwellings, nursing homes, hospitals, trailer parks, camping grounds, etc.),
- (b) institutional facilities (e.g.: schools, churches, community centres, day care centres, recreational centres, etc.),
- (c) outdoor public recreational areas (e.g.: trailer parks, play grounds, picnic areas, etc.), and
- (d) other outdoor public areas where there are continuous human activities (e.g.: commercial plazas and office buildings).

“**sub-system**” has the same meaning as in Ontario Regulation 128/04 (Certification of Drinking Water System Operators and Water Quality Analysts) under the SDWA;

“**surface water**” means water bodies (lakes, wetlands, ponds - including dug-outs), water courses (rivers, streams, water-filled drainage ditches), infiltration trenches, and areas of seasonal wetlands;

“**UV**” means ultraviolet, as in ultraviolet light produced from an ultraviolet reactor.

2.0 Applicability

- 2.1 In addition to any other applicable legal requirements, the drinking water system identified above shall be established, altered and operated in accordance with the conditions of the drinking water works permit and this licence.

3.0 Licence Expiry

- 3.1 This licence expires on the date identified as the licence expiry date in Schedule A of this licence.

4.0 Licence Renewal

- 4.1 Any application to renew this licence shall be made on or before the date identified as the application for licence renewal date set out in Schedule A of this licence.

5.0 Compliance

- 5.1 The owner and operating authority shall ensure that any person authorized to carry out work on or to operate any aspect of the drinking water system has been informed of the SDWA, all applicable regulations made in accordance with that act, the drinking water works permit and this licence and shall take all reasonable measures to ensure any such person complies with the same.

6.0 Licence and Drinking Water Works Permit Availability

- 6.1 At least one copy of this licence and the drinking water works permit shall be stored in such a manner that they are readily viewable by all persons involved in the operation of the drinking water system.

7.0 Permit to Take Water and Drinking Water Works Permit

- 7.1 A permit to take water identified in Schedule A of this licence is the applicable permit on the date identified as the Effective Date of this licence.
- 7.2 A drinking water works permit identified in Schedule A of this licence is the applicable permit on the date identified as the Effective Date of this licence.

8.0 Financial Plan

- 8.1 For every financial plan prepared in accordance with subsections 2(1) and 3(1) of O. Reg. 453/07, the owner of the drinking water system shall:
- 8.1.1 Ensure that the financial plan contains on the front page of the financial plan, the appropriate financial plan number as set out in Schedule A of this licence; and
- 8.1.2 Submit a copy of the financial plan to the Ministry of Municipal Affairs and Housing within three (3) months of receiving approval by a resolution of municipal council or the governing body of the owner.

9.0 Interpretation

- 9.1 Where there is a conflict between the provisions of this licence and any other document, the following hierarchy shall be used to determine the provision that takes precedence:
- 9.1.1 The SDWA;
- 9.1.2 A condition imposed in this licence that explicitly overrides a prescribed regulatory requirement;
- 9.1.3 A condition imposed in the drinking water works permit that explicitly overrides a prescribed regulatory requirement;
- 9.1.4 Any regulation made under the SDWA;
- 9.1.5 Any provision of this licence that does not explicitly override a prescribed regulatory requirement;
- 9.1.6 Any provision of the drinking water works permit that does not explicitly override a prescribed regulatory requirement;
- 9.1.7 Any application documents listed in this licence, or the drinking water works permit from the most recent to the earliest; and

- 9.1.8 All other documents listed in this licence, or the drinking water works permit from the most recent to the earliest.
- 9.1.9 Any other technical bulletin or procedure issued by the Ministry from the most recent to the earliest.
- 9.2** If any requirement of this licence or the drinking water works permit is found to be invalid by a court of competent jurisdiction, the remaining requirements of this licence and the drinking water works permit shall continue to apply.
- 9.3** The issuance of and compliance with the conditions of this licence and the drinking water works permit does not:
- 9.3.1 Relieve any person of any obligation to comply with any provision of any applicable statute, regulation or other legal requirement, including the *Environmental Assessment Act*, R.S.O. 1990, c. E.18; and
- 9.3.2 Limit in any way the authority of the appointed Directors and provincial officers of the Ministry to require certain steps be taken or to require the owner to furnish any further information related to compliance with the conditions of this licence or the drinking water works permit.
- 9.4** For greater certainty, nothing in this licence or the drinking water works permit shall be read to provide relief from regulatory requirements in accordance with section 46 of the SDWA, except as expressly provided in the licence or the drinking water works permit.

10.0 Adverse Effects

- 10.1** Nothing in this licence or the drinking water works permit shall be read as to permit:
- 10.1.1 The discharge of a contaminant into the natural environment that causes or is likely to cause an adverse effect; or
- 10.1.2 The discharge of any material of any kind into or in any waters or on any shore or bank thereof or into or in any place that may impair the quality of the water of any waters.
- 10.2** All reasonable steps shall be taken to minimize and ameliorate any adverse effect on the natural environment or impairment of the quality of water of any waters resulting from the operation of the drinking water system including such accelerated or additional monitoring as may be necessary to determine the nature and extent of the effect or impairment.
- 10.3** Fulfillment of one or more conditions imposed by this licence or the drinking water works permit does not eliminate the requirement to fulfill any other condition of this licence or the drinking water works permit.

11.0 Change of Owner or Operating Authority

- 11.1 This licence is not transferable without the prior written consent of the Director.
- 11.2 The owner shall notify the Director in writing at least 30 days prior to a change of any operating authority identified in Schedule A of this licence.
- 11.2.1 Where the change of operating authority is the result of an emergency situation, the owner shall notify the Director in writing of the change as soon as practicable.

12.0 Information to be Provided

- 12.1 Any information requested by a Director or a provincial officer concerning the drinking water system and its operation, including but not limited to any records required to be kept by this licence or the drinking water works permit, shall be provided upon request.

13.0 Records Retention

- 13.1 Except as otherwise required in this licence or the drinking water works permit, any records required by or created in accordance with this licence or the drinking water works permit, other than the records specifically referenced in section 12 or section 13 of O. Reg. 170/03, shall be retained for at least 5 years and made available for inspection by a provincial officer, upon request.

14.0 Chemicals and Materials

- 14.1 All chemicals and materials used in the alteration or operation of the drinking water system that come into contact with water within the system shall meet all applicable standards set by both the American Water Works Association ("AWWA") and the American National Standards Institute ("ANSI") safety criteria standards NSF/60, NSF/61 and NSF/372.
- 14.1.1 In the event that the standards are updated, the owner may request authorization from the Director to use any on hand chemicals and materials that previously met the applicable standards.
- 14.2 The most current chemical and material product registration documentation from a testing institution accredited by either the Standards Council of Canada or by the American National Standards Institution ("ANSI") shall be available at all times for each chemical and material used in the operation of the drinking water system that comes into contact with water within the system.
- 14.3 Conditions 14.1 and 14.2 do not apply in the case of the following:
- 14.3.1 Water pipe and pipe fittings meeting AWWA specifications made from ductile iron, cast iron, PVC, fibre and/or steel wire reinforced cement pipe or high density polyethylene (HDPE);
- 14.3.2 Articles made from stainless steel, glass, HDPE or Teflon®;

- 14.3.3 Cement mortar for watermain lining and for water contacting surfaces of concrete structures made from washed aggregates and Portland cement;
- 14.3.4 Gaskets that are made from NSF approved materials;
- 14.3.5 Food grade oils and lubricants, food grade anti-freeze, and other food grade chemicals and materials that are compatible for drinking water use that may come into contact with drinking water, but are not added directly to the drinking water; or
- 14.3.6 Any particular chemical or material where the owner has written documentation signed by the Director that indicates that the Ministry is satisfied that the chemical or material is acceptable for use within the drinking water system and the chemical or material is only used as permitted by the documentation.

15.0 Drawings

- 15.1 All drawings and diagrams in the possession of the owner that show any treatment subsystem as constructed shall be retained by the owner unless the drawings and diagrams are replaced by a revised or updated version showing the subsystem as constructed subsequent to the alteration.
- 15.2 Any alteration to any treatment subsystem shall be incorporated into process flow diagrams, process and instrumentation diagrams, and record drawings and diagrams within one year of the alteration being completed or placed into service.
- 15.3 Process flow diagrams and process and instrumentation diagrams for any treatment subsystem shall be kept in a place, or made available in such a manner, that they may be readily viewed by all persons responsible for all or part of the operation of the drinking water system.

16.0 Operations and Maintenance Manual

- 16.1 An up-to-date operations and maintenance manual or manuals shall be maintained and applicable parts of the manual or manuals shall be made available for reference to all persons responsible for all or part of the operation or maintenance of the drinking water system.
- 16.2 The operations and maintenance manual or manuals, shall include at a minimum:
 - 16.2.1 The requirements of this licence and associated procedures;
 - 16.2.2 The requirements of the drinking water works permit for the drinking water system;
 - 16.2.3 A description of the processes used to achieve primary and secondary disinfection within the drinking water system including where applicable:
 - a) A copy of the CT calculations that were used as the basis for primary disinfection under worst case operating conditions and other operating conditions, if applicable; and

- b) The validated operating conditions for UV disinfection equipment, including a copy of the validation certificate;
- 16.2.4 Procedures for monitoring and recording the in-process parameters necessary for the control of any treatment subsystem and for assessing the performance of the drinking water system;
 - 16.2.5 Procedures for the operation and maintenance of monitoring equipment;
 - 16.2.6 Contingency plans and procedures for the provision of adequate equipment and material to deal with emergencies, upset conditions and equipment breakdown;
 - 16.2.7 Procedures for dealing with complaints related to the drinking water system, including the recording of the nature of the complaint and any investigation and corrective action taken in respect of the complaint;
- 16.3** Procedures necessary for the operation and maintenance of any alterations to the drinking water system shall be incorporated into the operations and maintenance manual or manuals prior to those alterations coming into operation.
- 16.4** All of the procedures included or referenced within the operations and maintenance manual must be implemented.

Schedule C: System-Specific Conditions

System Owner	Arnprior, The Corporation of the Town of
Licence Number	170-101
Drinking Water System Name	Arnprior Drinking Water System
Licence Effective Date	March 31, 2021

1.0 System Performance

Rated Capacity

- 1.1** For each treatment subsystem listed in column 1 of Table 1, the maximum daily volume of treated water that flows from the treatment subsystem to the distribution system shall not exceed the value identified as the rated capacity in column 2 of the same row.

Table 1: Rated Capacity	
Column 1 Treatment Subsystem Name	Column 2 Rated Capacity (m ³ /day)
Walter E. Prentice Water Filtration Plant and Distribution System	10,340

Maximum Flow Rates

- 1.2** For each treatment subsystem listed in column 1 of Table 2, the maximum flow rate of water that flows into a treatment subsystem component listed in column 2 shall not exceed the value listed in column 3 of the same row.

Table 2: Maximum Flow Rates		
Column 1 Treatment Subsystem Name	Column 2 Treatment Subsystem Component	Column 3 Maximum Flow Rate (L/s)
Not Applicable	Not Applicable	Not Applicable

- 1.3** Despite conditions 1.1 and 1.2, a treatment subsystem may be operated temporarily at a maximum daily volume and/or a maximum flow rate above the values set out in column 2 of Table 1 and column 3 of Table 2 respectively for the purposes of fighting a large fire or for the maintenance of the drinking water system.
- 1.4** Condition 1.3 does not authorize the discharge into the distribution system of any water that does not meet all of the requirements of this licence and all other regulatory requirements, including compliance with the Ontario Drinking Water Quality Standards.

Residuals Management

- 1.5** In respect of an effluent discharged into the natural environment from a treatment subsystem or treatment subsystem component listed in column 1 of Table 3:
- 1.5.1 The annual average concentration of a test parameter identified in column 2 shall:
- not exceed the value in column 3 of the same row; and
 - be calculated at least once monthly as the running annual average based on the previous twelve months of results;
- 1.5.2 Where the average concentration of a test parameter identified in column 2 exceeds the value in column 3, the concentration shall be reported to the local Ministry district office within 72 hours of receipt of the last lab result used in the calculation;
- 1.5.3 The maximum concentration of a test parameter identified in column 2 shall not exceed the value in column 4 of the same row;
- 1.5.4 Where the maximum concentration of a test parameter identified in column 2 exceeds the value in column 4, the discharge shall be reported in accordance with s.13.2 of O. Reg. 675.98 and recorded in accordance with s.12.2 of O. Reg. 675.98 within 24 hours of receipt of the lab result; and,
- 1.5.5 The test parameters listed in column 2 of Table 3 shall be sampled in accordance with conditions 5.2, 5.3 and 5.4 of Schedule C in this Licence.

Table 3: Residuals Management			
Column 1 Treatment Subsystem or Treatment Subsystem Component Name	Column 2 Test Parameter	Column 3 Annual Average Concentration (mg/L)	Column 4 Maximum Concentration (mg/L)
Walter E. Prentice Water Filtration Plant and Distribution System – Filter backwash wastewater Residuals treatment	Annual average concentration of suspended solids in the effluent discharged from the filters backwash wastewater facilities	25	25
	Chlorine Residual	0.02	
Walter E. Prentice Water Filtration Plant and Distribution System – Actiflo Residuals treatment	Annual average concentration of suspended solids in the effluent discharged from the Actiflo Residuals treatment tank	25	25

UV Disinfection Equipment Performance

- 1.6** For each treatment subsystem or treatment subsystem component listed in column 1 of Table 4, and while directing water to the distribution system and being used to meet pathogen log removal/inactivation credits specified in Schedule E:
- 1.6.1 The UV disinfection equipment shall be operated within the validated limits for the equipment at all times such that a continuous pass-through UV dose is maintained throughout the life time of the UV lamp(s) that is at least the minimum continuous pass-through UV dose set out in column 2 of the same row
- 1.6.2 In addition to any other sampling, analysis and recording that may be required, the ultraviolet light disinfection equipment shall test for the test parameters set out in column 4 of the same row at a testing frequency of once every five (5) minutes or less and record the test data at a recording frequency of once every four (4) hours or less;
- 1.6.3 If there is a UV disinfection equipment alarm signaling that the disinfection equipment is malfunctioning, has lost power, or is not providing the appropriate level of disinfection the test parameters set out in column 4 of the same row shall be recorded at a recording frequency of once every five minutes or less until the alarm condition has been corrected;
- 1.6.4 A monthly summary report shall be prepared at the end of each calendar month which sets out the time, date and duration of each UV equipment alarm described in condition 1.6.3, the volume of water treated during each alarm period and the actions taken by the operating authority to correct the alarm situation;

Table 4: UV Disinfection Equipment			
Column 1 Treatment Subsystem or Treatment Subsystem Component Name	Column 2 Minimum Continuous Pass-Through UV Dose (mJ/cm²)	Column 3 Control Strategy	Column 4 Test Parameter
Not applicable	Not applicable	Not applicable	Not applicable

2.0 Flow Measurement and Recording Requirements

- 2.1** For each treatment subsystem identified in column 1 of Table 1 and in addition to any other flow measurement and recording that may be required, continuous flow measurement and recording shall be undertaken for:
- 2.1.1 The flow rate (L/s) and daily volume (m³/day) of treated water that flows from the treatment subsystem to the distribution system.
- 2.1.2 The flow rate (L/s) and daily volume (m³/day) of water that flows into the treatment subsystem.

- 2.2** For each treatment subsystem component identified in column 2 of Table 2 and in addition to any other flow measurement and recording that may be required, continuous flow measurement and recording shall be undertaken for the flow rate and daily volume of water that flows into the treatment subsystem component.
- 2.3** Where a rated capacity from Table 1 or a maximum flow rate from Table 2 is exceeded, the following shall be recorded:
- 2.3.1 The difference between the measured amount and the applicable rated capacity or maximum flow rate specified in Table 1 or Table 2;
 - 2.3.2 The time and date of the measurement;
 - 2.3.3 The reason for the exceedance; and
 - 2.3.4 The duration of time that lapses between the applicable rated capacity or maximum flow rate first being exceeded and the next measurement where the applicable rated capacity or maximum flow rate is no longer exceeded.

3.0 Calibration of Flow Measuring Devices

- 3.1** All flow measuring devices that are required by regulation, by a condition in the drinking water works permit 170-201, or by a condition otherwise imposed by the Ministry, shall be checked and where necessary calibrated in accordance with the manufacturer's instructions.
- 3.2** If the manufacturer's instructions do not indicate how often to check and calibrate a flow measuring device, the equipment shall be checked and where necessary calibrated at least once every 12 months during which the drinking water system is in operation.
- 3.2.1 For greater certainty, if condition 3.2 applies, the equipment shall be checked and where necessary calibrated not more than 30 days after the first anniversary of the day the equipment was checked and calibrated in the previous 12-month period.

4.0 Calibration of CT Monitoring System

- 4.1** Any measuring instrumentation that forms part of the monitoring system for CT shall be checked and where necessary calibrated at least once every 12 months during which the drinking water system is in operation, or more frequently in accordance with the manufacturer's instructions.
- 4.1.1 For greater certainty, if condition 4.1 applies, the instrumentation shall be checked and where necessary calibrated not more than 30 days after the first anniversary of the day the equipment was checked and calibrated in the previous 12-month period.

5.0 Additional Sampling, Testing and Monitoring

Drinking Water Health and Non-Health Related Parameters

- 5.1** For each treatment subsystem or treatment subsystem component identified in column 1 of Tables 5 and 6 and in addition to any other sampling, testing and monitoring that may be required, sampling, testing and monitoring shall be undertaken for a test parameter listed in column 2 at the sampling frequency listed in column 3 and at the monitoring location listed in column 4 of the same row.

Table 5: Drinking Water Health Related Parameters			
Column 1 Treatment Subsystem or Treatment Subsystem Component Name	Column 2 Test Parameter	Column 3 Sampling Frequency	Column 4 Monitoring Location
Walter E. Prentice Water Filtration Plant and Distribution System	Benzo(a)pyrene	Quarterly	Point of entrance to distribution system
	Nitrosodimethylamine (NDMA)	Quarterly	Farthest point in the distribution system

Table 6: Drinking Water Non-Health Related Parameters			
Column 1 Treatment Subsystem or Treatment Subsystem Component Name	Column 2 Test Parameter	Column 3 Sampling Frequency	Column 4 Monitoring Location
Walter E. Prentice Water Filtration Plant and Distribution System	Total Organic Carbon	Quarterly	Entrance to Distribution System
	Dissolved Organic Carbon	Quarterly	Entrance to Distribution System
	Colour	Quarterly	Entrance to Distribution System

Environmental Discharge Parameters

- 5.2** For each treatment subsystem or treatment subsystem component identified in column 1 of Table 7 and in addition to any other sampling, testing and monitoring that may be required, sampling, testing and monitoring shall be undertaken for a test parameter listed in column 2 using the sample type identified in column 3 at the sampling frequency listed in column 4 and at the monitoring location listed in column 5 of the same row.

- 5.3** For the purposes of Table 7:

- 5.3.1** Manual Composite means the mean of at least three grab samples taken during a discharge event, with one sample being taken immediately following the commencement of the discharge event, one sample being taken approximately at the mid-point of the discharge event and one sample being taken immediately before the end of the discharge event; and

5.3.2 Automated Composite means samples must be taken during a discharge event by an automated sampler at a minimum sampling frequency of once per hour.

5.4 Any sampling, testing and monitoring for the test parameter Total Suspended Solids shall be performed in accordance with the requirements set out in the publication "Standard Methods for the Examination of Water and Wastewater", 23rd Edition, 2017, or as amended from time to time by more recently published editions.

Table 7: Environmental Discharge Parameters

Column 1 Treatment Subsystem or Treatment Subsystem Component Name	Column 2 Test Parameter	Column 3 Sample Type	Column 4 Sampling Frequency	Column 5 Monitoring Location
Walter E. Prentice Water Filtration Plant and Distribution System – Filter backwash wastewater Residuals treatment	Suspended Solids (composite)	Composite	Monthly	Point of Discharge – Residue management supernatant discharge sampling port
	Total Chlorine Residual	Grab	Monthly	Point of Discharge – Residue management supernatant discharge sampling port
Walter E. Prentice Water Filtration Plant and Distribution System – Actiflo Residuals treatment	Suspended Solids (composite)	Composite	Monthly	Point of Discharge – Residue management supernatant discharge sampling port

5.5 Pursuant to Condition 10 of Schedule B of this licence, the owner may undertake the following environmental discharges associated with the maintenance and/or repair of the drinking water system:

5.5.1 The discharge of potable water from a watermain to a road or storm sewer;

5.5.2 The discharge of potable water from a water storage facility or pumping station:

a) To a road or storm sewer; or

b) To a watercourse where the discharge has been dechlorinated and if necessary, sediment and erosion control measures have been implemented.

5.5.3 The discharge of dechlorinated non-potable water from a watermain, water storage facility or pumping station to a road or storm sewer;

5.5.4 The discharge of raw water from a groundwater well to the environment where if necessary, sediment and erosion control measures have been implemented; and

5.5.5 The discharge of raw water, potable water or non-potable water from a treatment subsystem to the environment where if necessary, the discharge has been dechlorinated and sediment and erosion control measures have been implemented.

- 5.5.6 The discharge of any excess water to a road, storm sewer or the environment, associated with the management of materials excavated as part of watermain construction or repair, where necessary sediment, erosion and environmental control measures have been implemented.

6.0 Studies Required

Harmful Algal Blooms

- 6.1** The owner shall develop and keep up to date a Harmful Algal Bloom monitoring, reporting and sampling plan, herein known as the “Plan”, to be implemented when a potential harmful algal bloom is suspected or present. The owner shall have the Plan in place on or before September 30, 2021.
- 6.1.1 The owner must have a copy of the Plan available onsite at the drinking water system, for inspection upon request by Ministry staff.
- 6.1.2 The owner must implement the Plan annually during the harmful algal bloom season, during but not limited to the warm seasonal period between June 1 and October 31 each year, or as otherwise directed by the Ministry or the Medical Officer of Health.
- 6.1.3 The owner must train all relevant drinking water system staff on the Plan prior to the beginning of each warm season, as described in Condition 6.1.2.
- 6.2** For clarity, a Harmful Algal Bloom is considered suspected or occurring when:
- 6.2.1 the owner or operating authority has observed an algal bloom:
- a) near the shoreline at or near the source water intake(s) described in drinking water works permit #xxx, or
 - b) where the intake has an Intake Protection Zone in a source protection plan, within IPZ-1, or
 - c) within a circle that has a radius, measured from the intake, equal to the distance from the intake to the farthest edge of IPZ-2.
- 6.2.2 microcystin has been detected in a raw or treated water sample; and/or,
- 6.2.3 the owner has received any form of notification related to an algal bloom from the Ministry, a Medical Officer of Health, or the public; or,
- 6.2.4 the presence of or identification of cyanobacteria has been determined through optical probes or other analytic techniques used by the drinking water system.
- 6.3** The Plan described in condition 6.1 must include, at a minimum:
- 6.3.1 details relating to visual monitoring for harmful algal blooms at or near the drinking water system intake(s),

-
- a) as described in drinking water works permit #xxx, or
 - b) where the intake has an Intake Protection Zone in a source protection plan, within IPZ-1, or
 - c) within a circle that has a radius, measured from the intake, equal to the distance from the intake to the farthest edge of IPZ-2.
- 6.3.2 details relating to visual monitoring of shoreline; this is applicable to drinking water systems where the proximity of the intake(s) may be of concern.
- 6.3.3 details relating to reporting the observed or suspected harmful algal bloom, as described in section 6.2:
- a) to the Overall Responsible Operator(s) and/or Operator(s)-in-Charge if the blooms have been observed or suspected by a duty operator; the Plan shall include wording that directs relevant drinking water staff to follow the instructions provided by the Overall Responsible Operator(s) or the Operator(s)-in-Charge;
 - b) to the medical officer of health; and
 - c) to the local MECP representative and the Ministry's Spills Action Centre.,
- 6.3.4 a sampling plan, including the identification of sample location(s) and frequencies that at a minimum match those described in condition 6.4.
- 6.3.5 triggers that may increase the required sampling frequency;
- 6.3.6 up-to-date records that document staff training on the harmful algal bloom monitoring, reporting, and sampling procedures.
- 6.4** Any water samples collected under Condition 6.3.4 must be:
- 6.4.1 collected, at a minimum, once per week, or as otherwise directed by the Ministry or the medical officer of health;
 - 6.4.2 collected prior to any treatment, if the sample is taken from raw water;
 - 6.4.3 collected at the point of entry into the distribution system, if the sample is taken from treated water;
 - 6.4.4 collected from the shoreline by the drinking water system, if applicable based on Condition 6.3.1;
 - 6.4.5 submitted to a laboratory licensed to perform ELISA testing for total microcystin;
 - 6.4.6 repeatedly collected until 3 consecutive samples have shown non-detection of microcystin and the algal bloom is no longer suspected or visually observed.

6.5 Corrosion Control Implementation

- 6.5.1 The Owner shall implement the Town of Arnprior Corrosion Control Plan dated November 3, 2014 and as amended on December 8, 2016 monitor the effectiveness of the corrosion control measures.
- 6.5.2 The Owner shall prepare an Evaluation Report to assess the effectiveness of the corrosion control measures. The report shall contain the following information in 5.1.3 – 5.1.7, where applicable:
- 6.5.3 A list of all lead results and a summary of any key corrosion control parameter measurements at the point treated water enters the distribution system and premise plumbing with the frequencies identified in Table 1:

Table 1: Monitoring the Effectiveness of Preferred Measures			
Column 1 Parameters	Column 2 Point of Entry	Column 3 Distribution System	Column 4 Residential and Non-Residential Taps
Lead	Quarterly	4 samples minimum, annually	12 samples minimum, annually
Alkalinity	Quarterly	4 samples minimum, annually	12 samples minimum, annually
pH	SCADA (continuous)	4 samples minimum, annually	12 samples minimum, annually
Orthophosphate (and soda ash)	-	1/month ¹	As per Corrosion Control Plan
Other Parameters in Table 6.1 the Ministry's Guidance Document for Corrosion Control Monitoring, dated December 2009.	-	-	-

¹ - Orthophosphate samples to be collected at the Towns Water Pollution Control Centre sample tap.

- 6.5.4 A technical evaluation of the effectiveness of corrosion control measures including:
- Any key milestones of implementation, including equipment malfunction or upset conditions;
 - The ability to maintain operating conditions and inhibitor concentrations, in the distribution system and premise plumbing; and
 - The ability to achieve reduction in lead levels and other corrosion related parameters in the distribution system and premise plumbing.
- 6.5.5 A summary of lead levels and other metals monitored at the following locations, since implementation of corrosion control, and comparison to pre-implementation levels:
- Distribution system;
 - Residential plumbing; and,
 - Non-residential plumbing.

- 6.5.6 An evaluation of secondary impacts as a result of corrosion control implementation of corrosion control measures, including any:
- a) Customer feedback or water quality complaints, since implementation of corrosion control, with analysis of reasons;
 - b) Impacts on secondary disinfection, including biofilm formation; and,
 - c) Impacts on wastewater treatment plants receiving treated water from the owner, including estimates of increases in phosphorous loadings to the receiver, and comparison to effluent limits.
- 6.5.7 A summary of results of all other aspects of the Owner's lead mitigation strategy including:
- a) Lead service line replacement on public and private property;
 - b) Outreach and education, especially to populations vulnerable to lead in drinking water;
 - c) Faucet filter program, and,
 - d) Involvement of public health authorities.
- 6.6** The Corrosion Control Evaluation Report outlined in 5.1.2 shall cover each calendar year, and shall be submitted to the Director by March 31st, annually.
- 6.7** The lead sampling data shall be submitted every 6 months to the Ottawa District Office, no later than 30 days following the previous bi-annual sampling periods.

7.0 Source Protection

- 7.1** The owner of the drinking water system shall implement risk management measures, as appropriate, to manage any potential threat to drinking water that results from the operation of the drinking water system.
- 7.2** The owner of the system shall notify the Director in writing within thirty (30) days of any approved changes to an applicable source protection plan that impact the assessed threat level of a fuel oil system identified in Schedule A of drinking water works permit.
- 7.3** The notification required in condition 7.2 shall include:
- 7.3.1 A description of the changes and their impact on the assessed threat level of the fuel oil system(s); and,
 - 7.3.2 A timeline for re-assessing the threat level and providing the results of the assessment to the Director.

Schedule D: Conditions for Relief from Regulatory Requirements

System Owner	Arnprior, The Corporation of the Town of
Licence Number	170-101
Drinking Water System Name	Arnprior Drinking Water System
Licence Effective Date	March 31, 2021

No relief from regulatory requirements is authorized by the Director under section 46 of the SDWA in respect of the drinking water system.

Schedule E: Pathogen Log Removal/Inactivation Credits

System Owner	Arnprior, The Corporation of the Town of
Licence Number	170-101
Drinking Water System Name	Arnprior Drinking Water System
Licence Effective Date	March 31, 2021

1.0 Primary Disinfection Pathogen Log Removal/Inactivation Credits

Arnprior Water Filtration Plant

Madawaska River [SURFACE WATER]

Minimum Log Removal/ Inactivation Required	Cryptosporidium Oocysts	Giardia Cysts ^a	Viruses ^b
Arnprior Water Filtration Plant	2	3	4

^a At least 0.5 log inactivation of Giardia shall be achieved by the disinfection portion of the overall water treatment process.

^b At least 2 log inactivation of viruses shall be achieved by disinfection.

Log Removal/Inactivation Credits Assigned ^c	Cryptosporidium Oocysts	Giardia Cysts	Viruses
Conventional Filtration	2	2.5	2
Chlorination [CT: Clearwell]	-	0.5+	2+

^c Log removal/inactivation credit assignment is based on each treatment process being fully operational and the applicable log removal/inactivation credit assignment criteria being met.

Treatment Component	Log Removal/Inactivation Credit Assignment Criteria
Conventional Filtration	<ol style="list-style-type: none"> 1. A chemical coagulant shall be used at all times when the treatment plant is in operation; 2. Chemical dosages shall be monitored and adjusted in response to variations in raw water quality; 3. Effective backwash procedures shall be maintained including filter-to-waste or an equivalent procedure during filter ripening to ensure that effluent turbidity requirements are met at all times; 4. Filtrate turbidity shall be continuously monitored from each filter; and 5. Performance criterion for filtered water turbidity of less than or equal to 0.3 NTU in 95% of the measurements each month shall be met for each filter.
Chlorination	<ol style="list-style-type: none"> 1. Sampling and testing for free chlorine residual shall be carried out by continuous monitoring equipment in the treatment process at or near a location where the intended contact time has just been completed in accordance with the Ministry's Procedure for Disinfection of Drinking Water in Ontario; and 2. At all times, CT provided shall be greater than or equal to the CT required to achieve the log removal credits assigned.
Primary Disinfection Notes	



DRINKING WATER WORKS PERMIT

Permit Number: 170-201

Issue Number: 3

Pursuant to the *Safe Drinking Water Act, 2002*, S.O. 2002, c. 32, and the regulations made thereunder and subject to the limitations thereof, I hereby issue this drinking water works permit under Part V of the *Safe Drinking Water Act, 2002*, S.O. 2002, c. 32 to:

Arnprior, The Corporation of the Town of

105 Elgin St
Arnprior, ON K7S 0A8

For the following municipal residential drinking water system:

Arnprior Drinking Water System

This drinking water works permit includes the following:

Schedule	Description
Schedule A	Drinking Water System Description
Schedule B	General
Schedule C	All documents issued as Schedule C to this drinking water works permit which authorize alterations to the drinking water system
Schedule D	Process Flow Diagrams

Upon the effective date of this drinking water works permit #170-201, all previously issued versions of permit #170-201 are revoked and replaced by this permit.

DATED at TORONTO this 31st day of March, 2021

Signature

Aziz Ahmed, P.Eng.
Director
Part V, *Safe Drinking Water Act, 2002*

Schedule A: Drinking Water System Description

System Owner	Arnprior, The Corporation of the Town of
Permit Number	170-201
Drinking Water System Name	Arnprior Drinking Water System
Permit Effective Date	March 31, 2021

1.0 System Description

- 1.1 The following is a summary description of the works comprising the above drinking water system:

Overview

The **Arnprior Drinking Water System** consists of 1 drinking water treatment plant serving approximately a population of 8,795. The source is the Madawaska River. This system can be categorized as a conventional coagulation, flocculation, clarification, and filtration facility, with the chemically assisted clarification process being a two-train proprietary package unit. There are three dual-media filters; optional powdered activated and prechlorination systems, as well as full-time chlorination, fluoridation, soda ash and ammonia addition. Ammonia is added to produce chloramines for secondary disinfection; added when the treated water is pumped from clear wells to the distribution system and elevated water storage tank. There is approximately 57.8 km of distribution watermain.

Treatment Plant

Name	Arnprior Water Filtration Plant
Street Address	71 James Street, Arnprior Town, County of Renfrew
UTM Coordinates	NAD83, Zone 18, Easting: 394000 Northing: 5031220
System Type	Treatment and Distribution
Notes	a main building housing the treatment units and control, testing and monitoring equipment

Surface Water Supply

Intake Crib

Description	Concrete intake structure, pipe, screen,
Equipment	500 mm diameter intake pipe
Location	Located approximately 10m from the west riverbank, Madawaska River
Notes	

Low Lift Works

Wet Well

Description	33 m ³ (3 m x 3.2 m x 3.4 m deep) wet well, with three (3) low lift pumps.
Notes	Mesh intake screen

Low Lift Pumps

Description	A raw water low lift pumping station
Equipment	Two (2) vertical turbine and one (1) centrifugal raw water pumps each rated at 11,000 m ³ /d at a total dynamic head (TDH) of 25 m; one (1) duty and two (2) standby
Notes	Pumps convey raw water through a 400 mm raw watermain into the water treatment plant. Turbidity and pH analyzers, coagulant and prechlorination injection points, and two (2) 350 mm flow transmitters are installed on this line prior to the flash mixing process. The flow elements are installed after the watermain splits to packaged coagulation, flocculation, clarification system.

Coagulation/Flocculation

Coagulation/Flocculation Facilities

Description	Proprietary package for coagulation, flocculation and clarification, consisting of two (2) ballasted flocculation water treatment trains, complete with concrete tankage, each rated at a nominal capacity of 11,000 m ³ /day and each train consisting of the following:
Equipment (on each train)	one (1) automatically operated raw water inlet valve;
	one (1) flash mix tank having approximate inside dimensions of 1.1 m by 1.1 m by 3.6 m top water level, and working volume of approximately 4.4 m ³ , equipped with a mechanical mixer;
	one (1) coagulation tank having approximate inside dimensions of 2.5 m by 1.8 m by 3.6 m top water level, and working volume of approximately 16.2 m ³ , equipped with a mechanical mixer;
	one (1) injection tank having approximate inside dimensions of 2.5 m by 1.8 m by 3.6 m top water level, and working volume of approximately 16.2 m ³ , equipped with a mechanical mixer and polymer injection piping;
	one (1) maturation tank having approximate inside dimensions of 3.4 m by 3.9 m by 3.6 m top water level, and working volume of approximately 47.7 m ³ , equipped with a mechanical mixer and polymer injection piping;
	one (1) clarifier tank having approximate inside dimensions of 4.1 m by 3.9 m complete with a mechanical scraper and include settling module; one (1) recirculation pump for recycling settled sand and residuals to the hydrocyclones;
	one (1) hydrocyclone, complete with splitter box, for separating microsand and residuals and sending microsand back into the injection tank and to send the residuals to a common settling tank for both trains;
	one (1) clarified water turbidity monitor, one (1) raw water pH monitor and level monitors;
	a process control system;
Notes	

Filtration

Filters

Description	Three (3) dual media filters (two different filter designs)
Dimensions	Three (3) dual media (Sand/anthracite) filters with a total filter area of 97.5m ² (5.9m x 5.5m per filter, each with a maximum filtration rate of 7 m/hr (m ³ /m ² /hr) at maximum daily flow with one of the filters out of service); media consisting of a 400 mm sand layer and a 600 mm anthracite layer; a prefabricated underdrain system, complete with air scour
	An actuated valve on the outlet of each filter automatically controlled to maintain a constant filter flow rate; a flow meter, a differential pressure head loss transmitter, level transmitter and an on-line turbidimeter on each of the filters
	one (1) air blower rated for 500 L/s at 45 kPa
Notes	

Backwash Pumps

Description	A filter backwash system including a split case backwash pump drawing from the clearwell, with a butterfly valve providing a backup backwash system using distribution system pressure, requiring manual operation.
Capacity	Pump has a rated capacity of 34,350 m ³ /d at 15m TDH
Notes	Filtered water is conveyed through magnetic flow meters, combined into a common header and delivered to both clearwells (operating in series).

Backwash Residuals Treatment

Description	Filters backwash wastewater with polymer addition, the backwash residuals are clarified, the supernatant dechlorinated using sodium bisulphate and drained by gravity to the Madawaska River and sludge pumped to sanitary sewers.
Equipment	One (1) concrete residuals treatment tank with polymer addition, flocculators and gravity settling with an approximate nominal capacity of 63.0 m ³ (approx. 6.0 m x 3.0 m x 3.5 m top water level).
	Polymer system including a mixing tank and mixer, one (1) storage tank, secondary containment, and two (2) polymer chemical feed pumps (one duty and one standby) with automatic switchover;
	Two (2) mechanical flocculators to aid in mixing of polymer with residuals water in the settling tank;
	Dechlorination system for supernatant, comprised of two (2) sodium bisulphite chemical feed pumps (one duty, one standby) with automatic switchover, capable of supplying up to 0.5 L/min at a pressure of 100 kPa, with secondary containment for the sodium bisulphite supply; containers
	Three (3) sludge hoppers at tank bottom for sludge collection;
	Two (2) sludge pumps (one duty and one standby) each capable of delivering approximately 24 L/s at a TDH of 8.6 m to the sanitary forcemain;
Notes	An effluent sample is collected by Waterworks staff and analyzed for its chlorine sample, prior to being discharged to the Madawaska River.

Actiflo Settling Tanks Residuals Treatment

Description	Actiflo wastewater from the hydrocyclones is sent to a common residuals tank. This raw water residuals does not contain chlorine. The supernatant is drained by gravity to the Madawaska River and sludge to backwash sludge pumps and pumped to sanitary sewers.
Equipment	One concrete residuals treatment tank with gravity settling 6.0m (long), 3.0m (wide), 3.5m side water depth.
	Supernatant overflow weir and piping for discharge to storm sewer
	Three sludge sloped bottom hoppers
	Three automated sludge valves
	Two Actiflo/backwash sludge pumps
	A baffled sand settling box
Notes	A supernatant effluent sample is collected by Waterworks staff and analyzed for its total suspended solids prior to being discharged to the Madawaska River.

Clear Well and High Lift Works

Clear Wells

Description	Two clear wells in series
Dimensions	Volume of clearwell 1 is 2,167 m ³ .
	Volume of clearwell 2 is 1804m ³ .
Notes	Chlorine is added just prior to the first clearwell. Clearwell 1 consists of 2 cells divided by a concrete baffle wall and is hydraulically connected to Clearwell 2, which consists of a single cell divided by a concrete wall. Treated water passes through the clearwells and is conveyed to the high lift pump wet well. Soda ash for pH control is added in Clearwell 2.

High Lift Pump Station

Description	Pumps, meters and analyzers.
Equipment	Three (3) high lift pumps, each designed to deliver approximately 125 L/s at a TDH of 70m
	Finished water analyzers for Free and Total Chlorine, Turbidity, pH, and Fluoride, and a flow meter for treated water to the distribution system.
	400mm diameter treated water header connected to the distribution system
Notes	Pumps draw from second clearwell.

Emergency Power

Backup Power Supply

Description	400kW diesel engine standby power generator set located in a separate outdoor enclosure
Notes	With a 2,270 L double wall storage tank

Chemical Addition

Coagulant

Description	A liquid coagulant injection system.
Feed Point	Watermain immediately upstream of the flash mixing process.
Equipment	Two (2) coagulant chemical feed pumps (one duty and one standby) with automatic switchover.
	One (1) 22,700 L fibreglass reinforced plastic storage tank, with secondary containment;
	One (1) 8,000 L storage tank.
Notes	The system is sized for dosing aluminum chloride or other alternate liquid coagulant chemicals;

Polymer

Description	Polymer injection system
Feed Point	Three locations in the Actiflo Train, at the Injection tank, Maturation Tank and Hydrocyclones
Equipment	One (1) fibreglass mixing tank c/w mixer. Two (2) fibreglass storage tanks. Two Polymer Chemical Metering Pumps, one pump dedicated to each Actiflow unit.
Notes	Flow to each injection point is balanced using Rotameters in each dedicated line to the feed point.

Aqueous Ammonia

Description	Aqueous ammonia system
Feed Point	Between the clearwells
Equipment	Two (2) aqueous ammonia chemical feed pumps (one duty and one standby) with automatic switchover. flow meter between clearwells to pace ammonia; one (1) level sensor secondary containment for supply containers and day tank.
Notes	

Chlorine

Description	A disinfection system utilizing gas chlorination for prechlorination and primary disinfection.
Feed Point	Before the flash mixer for prechlorination and directly into the clearwell inlet for primary disinfection
Equipment	Chlorine gas storage facilities consisting of approximately twelve 68kg bottles stored on site, two scales (one duty and one standby) measuring the tared weight of chlorine the bottle; automatic switchover from duty to standby cylinder based on a preset bottle pressure Two (2) chlorinators (one duty, one standby), and using water from the distribution system as injection water, and an online chlorine residual analyzer to continuously monitor free chlorine residual in the treated water
Notes	

Hydrofluosilicic Acid

Description	A fluoridation storage and injection system
Feed Point	Effluent launders of the filters
Equipment	Two (2) double lined concrete bulk storage tanks with a total volume of 15.8 m ³ for the storage of hydrofluosilicic acid (HFS); One (1) magnetic drive chemical transfer pump to transfer HFS to a

	polyethylene day tank;
	One (1) diaphragm chemical feed pump.
Notes	

Soda Ash

Description	A hydrated soda ash feed system consisting of a 1000 kg bag dry chemical hopper station
Feed Point	Clearwell No. 2 influent line and alternate dosing point in the filter effluent launders
	one (1) volumetric screw feeder
	one (1) slurry mix tank and one day tank
	piping to convey the slurry to the Feed Points
	one (1) on-line pH analyzer for monitoring the pH of treated water
Notes	Used for pH adjustment. Provision for future volumetric screw feeder and pretreatment pH adjustment.

Instrumentation and Control

SCADA System

Description	Motor control center, PLC and SCADA to control and monitor plant process equipment, raw water, filtered water, backwash water and treated water flow meters including all related piping, electrical and mechanical works, plumbing and ventilation, yard piping, instrumentation and control and metering equipment required for a fully operable Water Filtration Plant
Notes	System control with data acquisition including various on-line analyzers and monitors, including the following regulatory equipment: <ul style="list-style-type: none"> - Turbidity Analyzers – Filter 1, 2 & 3 effluent - Free Cl Analyzer – Clearwell #1 effluent - Flow meter – Between Clearwell #1 & 2 - Level Monitor – Clearwell #1 & 2 - pH Analyzer – Clearwell #2 effluent Treated water - Fluoride Analyzer – Treated water - Total Cl Analyzer – Treated water - Flow meter – Treated water - Pressure Sensor – high lift discharge - Flow meter – raw water

Additional Instrumentation Supporting Regulatory Compliance

Description	Additional instrumentation supporting regulatory compliance.
Notes	<ul style="list-style-type: none"> - pH and temperature meter – Lab equipment (CT calculation) - Spectrophotometer – Lab Equipment - Turbidity analyzer – Lab Equipment

Elevated Storage Tanks

Elevated water tower

Location	433 Hartney Street, Arnprior, Ontario
UTM Coordinates	
Description	2,727 m ³ elevated composite water storage tank
Dimensions	2,727 m ³
Equipment	NA
Notes	

Watermains

1.2 Watermains within the distribution system comprise:

1.2.1 Watermains that have been set out in each document or file identified in column 1 of Table 1.

Table 1: Watermains	
Column 1 Document or File Name	Column 2 Date
Arnprior Water Distribution System Map	October 2020

1.2.2 Watermains that have been added, modified, replaced or extended further to the provisions of Schedule C of this drinking water works permit on or after the date identified in column 2 of Table 1 for each document or file identified in column 1.

1.2.3 Watermains that have been added, modified, replaced or extended further to an authorization by the Director on or after the date identified in column 2 of Table 1 for each document or file identified in column 1.

Schedule B: General

System Owner	Arnprior, The Corporation of the Town of
Permit Number	170-201
Drinking Water System Name	Arnprior Drinking Water System
Permit Effective Date	March 31, 2021

1.0 Applicability

- 1.1 In addition to any other applicable legal requirements, the drinking water system identified above shall be altered and operated in accordance with the conditions of this drinking water works permit and the licence #170-101.
- 1.2 The definitions and conditions of licence #170-101 are incorporated into this permit and also apply to this drinking water system.

2.0 Alterations to the Drinking Water System

- 2.1 Any document issued by the Director to be incorporated into Schedule C to this drinking water works permit shall provide authority to alter the drinking water system in accordance with the applicable conditions of this drinking water works permit and licence #170-101.
- 2.2 All documents issued by the Director as described in condition 2.1 shall form part of this drinking water works permit.
- 2.3 All parts of the drinking water system in contact with drinking water that are added, modified, replaced, extended shall be disinfected in accordance with a procedure approved by the Director or in accordance with the applicable provisions of the following documents:
 - a) Until **August 30, 2021**, the ministry's Watermain Disinfection Procedure, dated November 2015. As of **August 31, 2021**, the ministry's Watermain Disinfection Procedure, dated August 1, 2020;
 - b) Subject to condition 2.3.2, any updated version of the ministry's Watermain Disinfection Procedure;
 - c) AWWA C652 – Standard for Disinfection of Water-Storage Facilities;
 - d) AWWA C653 – Standard for Disinfection of Water Treatment Plants; and
 - e) AWWA C654 – Standard for Disinfection of Wells.
- 2.3.1 For greater clarity, where an activity has occurred that could introduce contamination, including but not limited to repair, maintenance, or physical / video inspection, all equipment that may come in contact with the drinking water system shall be disinfected in accordance with the requirements of condition 2.3. above.
- 2.3.2 Updated requirements described in condition 2.3 b) are effective six months from the date of publication of the updated Watermain Disinfection Procedure.

-
- 2.4 The owner shall notify the Director in writing within thirty (30) days of the placing into service or the completion of any addition, modification, replacement, removal or extension of the drinking water system which had been authorized through:
- 2.4.1 Schedule B to this drinking water works permit which would require an alteration of the description of a drinking water system component described in Schedule A of this drinking water works permit;
 - 2.4.2 Any document to be incorporated in Schedule C to this drinking water works permit respecting works other than watermains; or
 - 2.4.3 Any approval issued prior to the issue date of the first drinking water works permit respecting works other than watermains which were not in service at the time of the issuance of the first drinking water works permit.
- 2.5 The notification required in condition 2.4 shall be submitted using the "Director Notification Form" published by the Ministry.
- 2.6 For greater certainty, the notification requirements set out in condition 2.4 do not apply to any addition, modification, replacement, removal or extension in respect of the drinking water system which:
- 2.6.1 Is exempt from subsection 31(1) of the SDWA by subsection 9.(2) of O. Reg. 170/03;
 - 2.6.2 Constitutes maintenance or repair of the drinking water system; or
 - 2.6.3 Is a watermain authorized by condition 3.1 of Schedule B of this drinking water works permit.
- 2.7 The owner shall notify the legal owner of any part of the drinking water system that is prescribed as a municipal drinking water system by section 2 of O. Reg. 172/03 of the requirements of the licence and this drinking water works permit as applicable to the prescribed system.
- 2.8 For greater certainty, the owner may only carry out alterations to the drinking water system in accordance with this drinking water works permit after having satisfied other applicable legal obligations, including those arising from the *Environmental Assessment Act*, *Niagara Escarpment Planning and Development Act*, *Oak Ridges Moraine Conservation Act, 2001* and *Greenbelt Act, 2005*.

3.0 Watermain Additions, Modifications, Replacements and Extensions

- 3.1 The owner may alter the drinking water system, or permit it to be altered by a person acting on the owner's behalf, by adding, modifying, replacing or extending a watermain within the distribution system subject to the following conditions:
- 3.1.1 The design of the watermain addition, modification, replacement or extension:
 - a) Has been prepared by a licensed engineering practitioner;
 - b) Has been designed only to transmit water and has not been designed to treat water;

-
- c) Satisfies the design criteria set out in the Ministry publication “Watermain Design Criteria for Future Alterations Authorized under a Drinking Water Works Permit – June 2012”, as amended from time to time; and
 - d) Is consistent with or otherwise addresses the design objectives contained within the Ministry publication “Design Guidelines for Drinking Water Systems, 2008”, as amended from time to time.
- 3.1.2 The maximum demand for water exerted by consumers who are serviced by the addition, modification, replacement or extension of the watermain will not result in an exceedance of the rated capacity of a treatment subsystem or the maximum flow rate for a treatment subsystem component as specified in the licence, or the creation of adverse conditions within the drinking water system.
 - 3.1.3 The watermain addition, modification, replacement or extension will not adversely affect the distribution system’s ability to maintain a minimum pressure of 140 kPa at ground level at all points in the distribution system under maximum day demand plus fire flow conditions.
 - 3.1.4 Secondary disinfection will be provided to water within the added, modified, replaced or extended watermain to meet the requirements of O. Reg. 170/03.
 - 3.1.5 The watermain addition, modification, replacement or extension is wholly located within the municipal boundary over which the owner has jurisdiction.
 - 3.1.6 The owner of the drinking water system consents in writing to the watermain addition, modification, replacement or extension.
 - 3.1.7 A licensed engineering practitioner has verified in writing that the watermain addition, modification, replacement or extension meets the requirements of condition 3.1.1.
 - 3.1.8 The owner of the drinking water system has verified in writing that the watermain addition, modification, replacement or extension meets the requirements of conditions 3.1.2 to 3.1.6.
- 3.2 The authorization for the addition, modification, replacement or extension of a watermain provided for in condition 3.1 does not include the addition, modification, replacement or extension of a watermain that:
 - 3.2.1 Passes under or through a body of surface water, unless trenchless construction methods are used;
 - 3.2.2 Has a nominal diameter greater than 750 mm;
 - 3.2.3 Results in the fragmentation of the drinking water system; or
 - 3.2.4 Connects to another drinking water system, unless:
 - a) Prior to construction, the owner of the drinking water system seeking the connection obtains written consent from the owner or owner’s delegate of the drinking water system being connected to; and

- b) The owner of the drinking water system seeking the connection retains a copy of the written consent from the owner or owner's delegate of the drinking water system being connected to as part of the record that is recorded and retained under condition 3.3.
- 3.3 The verifications required in conditions 3.1.7 and 3.1.8 shall be:
- 3.3.1 Recorded on "Form 1 – Record of Watermains Authorized as a Future Alteration", as published by the Ministry, prior to the watermain addition, modification, replacement or extension being placed into service; and
- 3.3.2 Retained for a period of ten (10) years by the owner.
- 3.4 For greater certainty, the verification requirements set out in condition 3.3 do not apply to any addition, modification, replacement or extension in respect of the drinking water system which:
- 3.4.1 Is exempt from subsection 31(1) of the SDWA by subsection 9.(2) of O. Reg. 170/03; or
- 3.4.2 Constitutes maintenance or repair of the drinking water system.
- 3.5 The document or file referenced in Column 1 of Table 1 of Schedule A of this drinking water works permit that sets out watermains shall be retained by the owner and shall be updated to include watermain additions, modifications, replacements and extensions within 12 months of the addition, modification, replacement or extension.
- 3.6 The updates required by condition 3.5 shall include watermain location relative to named streets or easements and watermain diameter.
- 3.7 Despite clause (a) of condition 3.1.1 and condition 3.1.7, with respect to the replacement of an existing watermain or section of watermain that is 6.1 meters in length or less, if a licensed engineering practitioner has:
- 3.7.1 inspected the replacement prior to it being put into service;
- 3.7.2 prepared a report confirming that the replacement satisfies clauses (b), (c) and (d) of condition 3.1.1 (i.e. "Form 1 – Record of Watermains Authorized by a Future Alteration" (Form 1), Part 3, items No. 2, 3 and 4); and
- 3.7.3 appended the report referred to in condition 3.7.2 to the completed Form 1,
- the replacement is exempt from the requirements that the design of the replacement be prepared by a licensed engineering practitioner and that a licensed engineering practitioner verify on Form 1, Part 3, item No. 1 that a licensed engineering practitioner prepared the design of the replacement.
- 3.8 For greater certainty, the exemption in condition 3.7 does not apply to the replacement of an existing watermain or section of watermain if two or more sections of pipe, each of which is 6.1 meters in length or less, are joined together, if the total length of replacement pipes joined together is greater than 6.1 meters.

4.0 Minor Modifications to the Drinking Water System

- 4.1 The drinking water system may be altered by adding, modifying or replacing the following components in the drinking water system:
- 4.1.1 Coagulant feed systems in the treatment system, including the location and number of dosing points:
 - a) Prior to making any alteration to the drinking water system under condition 4.1.1, the owner shall undertake a review of the impacts that the alteration might have on corrosion control or other treatment processes; and
 - b) The owner shall notify the Director in writing within thirty (30) days of any alteration made under condition 4.1.1 and shall provide the Director with a copy of the review.
 - c) The notification required in condition 4.1.1 b) shall be submitted using the "Director Notification Form" published by the Ministry
 - 4.1.2 Instrumentation and controls, including new SCADA systems and upgrades to SCADA system hardware;
 - 4.1.3 SCADA system software or programming that:
 - a) Measures, monitors or reports on a regulated parameter;
 - b) Measures, monitor or reports on a parameter that is used to calculate CT; or,
 - c) Calculates CT for the system or is part of the process algorithm that calculates log removal, where the impacts of addition, modification or replacement have been reviewed by a licensed engineering practitioner;
 - 4.1.4 Filter media, backwashing equipment, filter troughs, and under-drains and associated equipment in the treatment system;
 - 4.1.5 Spill containment works; or,
 - 4.1.6 Coarse screens and fine screens
- 4.2 The drinking water system may be altered by adding, modifying, replacing or removing the following components in the drinking water system:
- 4.2.1 Treated water pumps, pressure tanks, and associated equipment;
 - 4.2.2 Raw water pumps and process pumps in the treatment system;
 - 4.2.3 Inline booster pumping stations that are not associated with distribution system storage facilities and are on a watermain with a nominal diameter not exceeding 200 mm;
 - 4.2.4 Re-circulation devices within distribution system storage facilities;

- 4.2.5 In-line mixing equipment;
 - 4.2.6 Chemical metering pumps and chemical handling pumps;
 - 4.2.7 Chemical storage tanks (excluding fuel storage tanks) and associated equipment; or,
 - 4.2.8 Measuring and monitoring devices that are not required by regulation, by a condition in the Drinking Water Works Permit, or by a condition otherwise imposed by the Ministry.
 - 4.2.9 Chemical injection points;
 - 4.2.10 Valves.
- 4.3 The drinking water system may be altered by replacing the following:
- 4.3.1 Raw water piping, treatment process piping or treated water piping within the treatment subsystem;
 - 4.3.2 Measuring and monitoring devices that are required by regulation, by a condition in the Drinking Water Works Permit or by a condition otherwise imposed by the Ministry.
 - 4.3.3 Coagulants and pH adjustment chemicals, where the replacement chemicals perform the same function;
 - a) Prior to making any alteration to the drinking water system under condition 4.3.3, the owner shall undertake a review of the impacts that the alteration might have on corrosion control or other treatment processes; and
 - b) The owner shall notify the Director in writing within thirty (30) days of any alteration made under condition 4.3.3 and shall provide the Director with a copy of the review.
 - c) The notification required in condition 4.3.3 b) shall be submitted using the "Director Notification Form" published by the Ministry.
- 4.4 Any alteration of the drinking water system made under conditions 4.1, 4.2 or 4.3 shall not result in:
- 4.4.1 An exceedance of a treatment subsystem rated capacity or a treatment subsystem component maximum flow rate as specified in the licence;
 - 4.4.2 The bypassing or removal of any unit process within a treatment subsystem;
 - 4.4.3 The addition of any new unit process other than coagulation within a treatment subsystem;
 - 4.4.4 A deterioration in the quality of drinking water provided to consumers;

- 4.4.5 A reduction in the reliability or redundancy of any component of the drinking water system;
 - 4.4.6 A negative impact on the ability to undertake compliance and other monitoring necessary for the operation of the drinking water system; or
 - 4.4.7 An adverse effect on the environment.
- 4.5 The owner shall verify in writing that any addition, modification, replacement or removal of drinking water system components in accordance with conditions 4.1, 4.2 or 4.3 has met the requirements of the conditions listed in condition 4.4.
- 4.6 The verifications and documentation required in condition 4.5 shall be:
- 4.6.1 Recorded on “Form 2 – Record of Minor Modifications or Replacements to the Drinking Water System” published by the Ministry, prior to the modified or replaced components being placed into service; and
 - 4.6.2 Retained for a period of ten (10) years by the owner.
- 4.7 For greater certainty, the verification requirements set out in conditions 4.5 and 4.6 do not apply to any addition, modification, replacement or removal in respect of the drinking water system which:
- 4.7.1 Is exempt from subsection 31(1) of the SDWA by subsection 9.(2) of O. Reg. 170/03; or
 - 4.7.2 Constitutes maintenance or repair of the drinking water system, including software changes to a SCADA system that are not listed in condition 4.1.3
- 4.8 The owner shall update any drawings maintained for the drinking water system to reflect the modification or replacement of the works, where applicable.

5.0 Equipment with Emissions to the Air

- 5.1 The drinking water system may be altered by adding, modifying or replacing any of the following drinking water system components that may discharge or alter the rate or manner of a discharge of a compound of concern to the air:
- 5.1.1 Any equipment, apparatus, mechanism or thing that is used for the transfer of outdoor air into a building or structure that is not a cooling tower;
 - 5.1.2 Any equipment, apparatus, mechanism or thing that is used for the transfer of indoor air out of a space used for the production, processing, repair, maintenance or storage of goods or materials, including chemical storage;
 - 5.1.3 Laboratory fume hoods used for drinking water testing, quality control and quality assurance purposes;
 - 5.1.4 Low temperature handling of compounds with a vapor pressure of less than 1 kilopascal;

- 5.1.5 Maintenance welding stations;
 - 5.1.6 Minor painting operations used for maintenance purposes;
 - 5.1.7 Parts washers for maintenance shops;
 - 5.1.8 Emergency chlorine and ammonia gas scrubbers and absorbers;
 - 5.1.9 Venting for activated carbon units for drinking water taste and odour control;
 - 5.1.10 Venting for a stripping unit for methane removal from a groundwater supply;
 - 5.1.11 Venting for an ozone treatment unit;
 - 5.1.12 Natural gas or propane fired boilers, water heaters, space heaters and make-up air units with a total facility-wide heat input rating of less than 20 million kilojoules per hour, and with an individual fuel energy input of less than or equal to 10.5 gigajoules per hour; or
 - 5.1.13 Emergency generators that fire No. 2 fuel oil (diesel fuel) with a sulphur content of 0.5 per cent or less measured by weight, natural gas, propane, gasoline or biofuel, and that are used for emergency duty only with periodic testing.
- 5.2 The owner shall not make an addition, modification, or replacement described in condition 5.1 in relation to an activity that is not related to the treatment and/or distribution of drinking water.
- 5.3 The emergency generators identified in condition 5.1.13 shall not be used for non-emergency purposes including the generation of electricity for sale or for peak shaving purposes.
- 5.4 The owner shall prepare an emission summary table for nitrogen oxides emissions only, for each addition, modification or replacement of emergency generators identified in condition 5.1.13.

Performance Limits

- 5.5 The owner shall ensure that a drinking water system component identified in conditions 5.1.1 to 5.1.13 is operated at all times to comply with the following limits:
- 5.5.1 For equipment other than emergency generators, the maximum concentration of any compound of concern at a point of impingement shall not exceed the corresponding point of impingement limit;
 - 5.5.2 For emergency generators, the maximum concentration of nitrogen oxides at sensitive receptors shall not exceed the applicable point of impingement limit, and at non-sensitive receptors shall not exceed the Ministry half-hourly screening level of 1880 ug/m³ as amended; and
 - 5.5.3 The noise emissions comply at all times with the limits set out in publication NPC-300, as applicable.

- 5.6 The owner shall verify in writing that any addition, modification or replacement of works in accordance with condition 5.1 has met the requirements of the conditions listed in condition 5.5.
- 5.7 The owner shall document how compliance with the performance limits outlined in condition 5.5.3 is being achieved, through noise abatement equipment and/or operational procedures.
- 5.8 The verifications and documentation required in conditions 5.6 and 5.7 shall be:
- 5.8.1 Recorded on "Form 3 – Record of Addition, Modification or Replacement of Equipment Discharging a Contaminant of Concern to the Atmosphere", as published by the Ministry, prior to the additional, modified or replacement equipment being placed into service; and
- 5.8.2 Retained for a period of ten (10) years by the owner.
- 5.9 For greater certainty, the verification and documentation requirements set out in conditions 5.6 and 5.8 do not apply to any addition, modification or replacement in respect of the drinking water system which:
- 5.9.1 Is exempt from subsection 31(1) of the SDWA by subsection 9.(2) of O. Reg. 170/03; or
- 5.9.2 Constitutes maintenance or repair of the drinking water system.
- 5.10 The owner shall update any drawings maintained for the works to reflect the addition, modification or replacement of the works, where applicable.

6.0 Previously Approved Works

- 6.1 The owner may add, modify, replace or extend, and operate part of a municipal drinking water system if:
- 6.1.1 An approval was issued after January 1, 2004 under section 36 of the SDWA in respect of the addition, modification, replacement or extension and operation of that part of the municipal drinking water system;
- 6.1.2 The approval expired by virtue of subsection 36(4) of the SDWA; and
- 6.1.3 The addition, modification, replacement or extension commenced within five years of the date that activity was approved by the expired approval.

7.0 System-Specific Conditions

- 7.1 Not Applicable

8.0 Source Protection

- 8.1 Not Applicable

Schedule C: Authorization to Alter the Drinking Water System

System Owner	Arnprior, The Corporation of the Town of
Permit Number	170-201
Drinking Water System Name	Arnprior Drinking Water System
Permit Effective Date	March 31, 2021

1.0 General

1.1 Table 2 provides a reference list of all documents to be incorporated into Schedule C that have been issued as of the date that this permit was issued.

1.1.1 Table 2 is not intended to be a comprehensive list of all documents that are part of Schedule C. For clarity, any document issued by the Director to be incorporated into Schedule C after this permit has been issued is considered part of this drinking water works permit.

Table 2: Schedule C Documents				
Column 1 Issue #	Column 2 Issued Date	Column 3 Description	Column 4 Status	Column 5 DN#
1	May 19, 2016	Implementation of Corrosion Control Plan	Approved	Not Applicable

1.2 For each document described in columns 1, 2 and 3 of Table 2, the status of the document is indicated in column 4. Where this status is listed as 'Archived', the approved alterations have been completed and relevant portions of this permit have been updated to reflect the altered works. These 'Archived' Schedule C documents remain as a record of the alterations.

Schedule D: Process Flow Diagrams

System Owner	Arnprior, The Corporation of the Town of
Permit Number	170-201
Drinking Water System Name	Arnprior Drinking Water System
Permit Effective Date	March 31, 2021

1.0 Process Flow Diagrams

Arnprior Water Filtration Plant

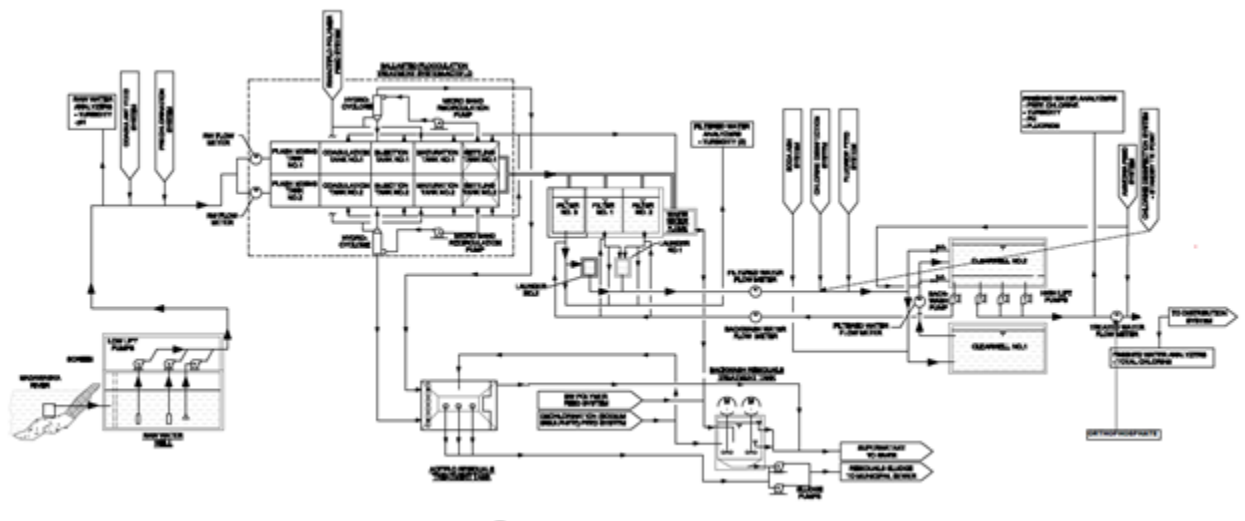

[Source: 2 and 3 - Town of Arnprior DWQMS Operational Plan - Version 16 - March 13, 2020]

Note: this process flow diagram is for reference only, and represents a high level overview of the system as of March 13, 2020.

APPENDIX B
PERMIT TO TAKE WATER

PERMIT TO TAKE WATER

Surface Water

NUMBER P-300-1179150700

Version: 1.0

Effective Date: August 10, 2022

Expiry Date: August 9, 2032

Pursuant to Section 34.1 of the Ontario Water Resources Act, Revised Statutes of Ontario (R.S.O.) 1990 this Permit To Take Water is hereby issued to:

CORPORATION OF THE TOWN OF ARNPRIOR

105 ELGIN Street West

Arnprior

ONTARIO

Canada

K7S0A8

For the water taking from

Madawaska River

Located at:

71 James Street , Arnprior, ARNPRIOR, ONTARIO, CANADA, K7S 1C9

This Permit cancels and replaces Permit Number 4143-8ZDLMJ, issued on October 23, 2012.

DEFINITIONS

For the purposes of this Permit, and the terms and conditions specified below, the following definitions apply:

- a. "Director" means any person appointed in writing as a director pursuant to section 5 of the OWRA for the purposes of section 34.1 of the OWRA.
- b. "Provincial Officer" means any person designated in writing by the Minister as a provincial officer pursuant to section 5 of the OWRA.
- c. "Ministry" means the ministry of the government of Ontario responsible for the administration of the OWRA, currently named the Ministry of the Environment, Conservation and Parks.
- d. "District Office" means the Ottawa District Office of the Ministry.
- e. "Permit" or "PTTW" means this Permit to Take Water No. P-300-1179150700 including its Schedules, if any, issued in accordance with Section 34.1 of the OWRA, as may amended.
- f. "Permit Holder" means CORPORATION OF THE TOWN OF ARNPRIOR.
- g. "OWRA" means the *Ontario Water Resources Act*, R.S.O. 1990, c. O. 40.

TERMS AND CONDITIONS

You are hereby notified that this Permit is issued subject to the terms and conditions outlined below:

1. Compliance with Permit

- 1.1. Except where modified by this Permit, the water taking shall be in accordance with the application for this Permit To Take Water, attested to by John Steckly, on May 11, 2022, and all Schedules included in this Permit.
- 1.2. The Permit Holder shall ensure that any person authorized by the Permit Holder to take water under this Permit is provided with a copy of this Permit and shall take all reasonable measures to ensure that any such person complies with the conditions of this Permit.
- 1.3. Any person authorized by the Permit Holder to take water under this Permit shall comply with the conditions of this Permit.
- 1.4. This Permit is not transferable to another person.
- 1.5. This Permit provides the Permit Holder with permission to take water in accordance with the conditions of this Permit, up to the date of the expiry of this Permit. This Permit does not constitute a legal right, vested or otherwise, to a water allocation, and the issuance of this Permit does not guarantee that, upon its expiry, it will be renewed.
- 1.6. The Permit Holder shall keep this Permit available at all times at or near the site of the taking, and shall produce this Permit immediately for inspection by a Provincial Officer upon his or her request.
- 1.7. The Permit Holder shall report any changes of address to the Director within thirty days of any such change. The Permit Holder shall report any change of ownership of the property for which this Permit is issued within thirty days of any such change. A change in ownership in the property shall cause this Permit to be cancelled.

2. General Conditions and Interpretation

2.1. Inspections

The Permit Holder must forthwith, upon presentation of credentials, permit a Provincial Officer to carry out any and all inspections authorized by the OWRA, the Environmental Protection Act, R.S.O. 1990, the Pesticides Act, R.S.O. 1990, or the Safe Drinking Water Act, S. O. 2002.

2.2. Other Approvals

The issuance of, and compliance with this Permit, does not:

- (a) relieve the Permit Holder or any other person from any obligation to comply with any other applicable legal requirements, including the provisions of the Ontario Water Resources Act, and the Environmental Protection Act, and any regulations made thereunder; or
- (b) limit in any way any authority of the Ministry, a Director, or a Provincial Officer, including the authority to require certain steps be taken or to require the Permit Holder to furnish any further information related to this Permit.

- 2.3. No water taken under the authority of this Permit may be discharged directly to the natural environment without prior treatment in accordance with an OWRA, R.S.O. 1990, Section 53, Industrial Sewage Works Approval.

2.4. Information

The receipt of any information by the Ministry, the failure of the Ministry to take any action or require any person to take any action in relation to the information, or the failure of a Provincial Officer to prosecute any person in relation to the information, shall not be construed as:

- (a) an approval, waiver or justification by the Ministry of any act or omission of any person that contravenes this Permit or other legal requirement; or
- (b) acceptance by the Ministry of the information's completeness or accuracy.

2.5. Rights of Action

The issuance of, and compliance with this Permit shall not be construed as precluding or limiting any legal claims or rights of action that any person, including the Crown in right of Ontario or any agency thereof, has or may

have against the Permit Holder, its officers, employees, agents, and contractors.

2.6. Severability

The requirements of this Permit are severable. If any requirements of this Permit, or the application of any requirements of this Permit to any circumstance, is held invalid or unenforceable, the application of such requirements to other circumstances and the remainder of this Permit shall not be affected thereby.

2.7. Conflicts

Where there is a conflict between a provision of any submitted document referred to in this Permit, including its Schedules, and the conditions of this Permit, the conditions in this Permit shall take precedence.

3. Water Takings Authorized by This Permit

3.1. Expiry

This Permit expires on August 9, 2032. No water shall be taken under authority of this Permit after the expiry date.

3.2. Amounts of Taking Permitted

The Permit Holder shall only take water from the source, during the periods and at the rates and amounts of taking specified in Table A. Water takings are authorized only for the purposes specified in Table A.

Table A (litres)

	Source Name / Description	Source Type	Purpose Category	Specific Purpose	Activity	Maximum Taken per minute	Maximum Number of Hours Taken per day	Maximum volume per Day	Maximum days in a year	Zone / Easting / Northing
1	Madawaska River (WFP)	WaterCourse	Utilities	Municipal Supply	Water Supply	7200	24	10340000	365	18 / 394158 / 5031193
Total Taking								10340000		

4. Monitoring

4.1. The Permit Holder shall maintain a record of all water takings. The daily volume of water taken shall be measured by a flow meter or calculated in accordance with the method described in the application for this Permit, or as otherwise accepted by the Director. This record shall include the dates and times of water takings, the rates of pumping, and an estimated calculation of the total amounts of water pumped per day for each day that water is taken under the authorization of this Permit. A separate record shall be maintained for each source. The Permit Holder shall keep all required records up to date and available at or near the site of the taking and shall produce the records immediately for inspection by a Provincial Officer upon his or her request. The Permit Holder, unless otherwise required by the Director, shall submit, on or before March 31st in every year, the records required by this condition to the Ministry's Regulatory Self Reporting System.

5. Impacts of the Water Taking

5.1. Notification

The Permit Holder shall immediately notify the local District Office of any complaint arising from the taking of water authorized under this Permit and shall report any action which has been taken or is proposed with regard to such complaint. The Permit Holder shall immediately notify the local District Office if the taking of water is observed to have any significant impact on the surrounding waters. After hours, calls shall be directed to the Ministry's Spills Action Centre at 1-800-268-6060.

5.2. Impacts for Water Situation Type

For Surface-Water Takings

The taking of water (including the taking of water into storage and the subsequent or simultaneous withdrawal from storage) shall be carried out in such a manner that streamflow is not stopped and is not reduced to a rate that will cause interference with downstream uses of water or with the natural functions of the stream.

For Groundwater Takings

If the taking of water is observed to cause any negative impact to other water supplies obtained from any adequate sources that were in use prior to initial issuance of a Permit for this water taking, the Permit Holder shall take such action necessary to make available to those affected, a supply of water equivalent in quantity and quality to their normal takings, or shall compensate such persons for their reasonable costs of so doing, or shall reduce the rate and amount of taking to prevent or alleviate the observed negative impact. Pending permanent restoration of the affected supplies, the Permit Holder shall provide, to those affected, temporary water supplies adequate to meet their normal requirements, or shall compensate such persons for their reasonable costs of doing so.

If permanent interference is caused by the water taking, the Permit Holder shall restore the water supplies of those permanently affected.

6. Director May Amend Permit

- 6.1. The Director may amend this Permit by letter requiring the Permit Holder to suspend or reduce the taking to an amount or threshold specified by the Director in the letter. The suspension or reduction in taking shall be effective immediately and may be revoked at any time upon notification by the Director. This condition does not affect your right to appeal the suspension or reduction in taking to the Environmental Review Tribunal under the Ontario Water Resources Act, Section 100 (4).

REASONS

The reasons for the imposition of these terms and conditions are as follows:

1. Condition 1 is included to ensure that the conditions in this Permit are complied with and can be enforced.
2. Condition 2 is included to clarify the legal interpretation of aspects of this Permit.
3. Conditions 3 through 6 are included to protect the quality of the natural environment so as to safeguard the ecosystem and human health and foster efficient use and conservation of waters. These conditions allow for the beneficial use of waters while ensuring the fair sharing, conservation and sustainable use of the waters of Ontario. The conditions also specify the water takings that are authorized by this Permit and the scope of this Permit.

APPEAL PROVISIONS

In accordance with Section 100 of the *Ontario Water Resources Act, R.S.O. 1990*, you may by written notice served upon me and the Ontario Land Tribunal within 15 days after receipt of this notice, require a hearing by the Tribunal. Section 101 of the *Ontario Water Resources Act, R.S.O. 1990*, as amended, provides that the notice requiring the hearing ("the Notice") shall state:

1. The portions of the Permit or each term or condition in the Permit in respect of which the hearing is required, and;
2. The grounds on which you intend to rely at the hearing in relation to each portion appealed.

In addition to these legal requirements, the Notice should also include:

- a. The name of the appellant;
- b. The address of the appellant;
- c. The permit to take water number;
- d. The date of the permit to take water;
- e. The name of the Director;
- f. The municipality within which the works are located;

This Notice must be served upon:

Registrar*		The Director, Section 34.1,
Ontario Land Tribunal		Ministry of the Environment, Conservation and Parks
655 Bay Street, Suite 1500	and	5775 Yonge Street, 8 th Floor
Toronto ON		Toronto, ON
M5G 1E5		M2M 4J1
OLT.Registrar@ontario.ca		Fax: (416) 325-6347

*** Further information on the Ontario Land Tribunal's requirements for an appeal can be obtained directly from the Tribunal at: Tel: (416) 212-6349 or 1 (866) 448-2248, or www.olt.gov.on.ca**

Dated at Kingston this 9th day of August, 2022

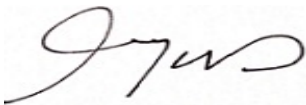

Archana Uprety

Director, Section 34.1

Ontario Water Resources Act, R.S.O. 1990

c: John Steckly, CORPORATION OF THE TOWN OF ARNPRIOR

SCHEDULE 1

This Schedule "A" forms part of Permit To Take Water P-300-1179150700 Version Number 1.0, dated August 9, 2022.

APPENDIX C
STAKEHOLDER SUPPORT

Key Reference and Guidance Material for Municipal Residential Drinking Water Systems

Many useful materials are available to help you operate your drinking water system. Below is a list of key materials owners and operators of municipal residential drinking water systems frequently use.

To access these materials online click on their titles in the table below or use your web browser to search for their titles. Contact the Ministry if you need assistance or have questions at 1-866-793-2588 or waterforms@ontario.ca.

For more information on Ontario's drinking water visit www.ontario.ca/drinkingwater



PUBLICATION TITLE	PUBLICATION NUMBER
FORMS: Drinking Water System Profile Information Laboratory Services Notification Adverse Test Result Notification	012-2149E 012-2148E 012-4444E
Taking Care of Your Drinking Water: A Guide for Members of Municipal Councils	Website
Procedure for Disinfection of Drinking Water in Ontario	Website
Strategies for Minimizing the Disinfection Products Trihalomethanes and Haloacetic Acids	Website
Filtration Processes Technical Bulletin	Website
Ultraviolet Disinfection Technical Bulletin	Website
Guide for Applying for Drinking Water Works Permit Amendments, & License Amendments	Website
Certification Guide for Operators and Water Quality Analysts	Website
Guide to Drinking Water Operator Training Requirements	9802E
Community Sampling and Testing for Lead: Standard and Reduced Sampling and Eligibility for Exemption	Website
Drinking Water System Contact List	7128E01
Ontario's Drinking Water Quality Management Standard - Pocket Guide	Website
Watermain Disinfection Procedure	Website
List of Licensed Laboratories	Website

Principaux guides et documents de référence sur les réseaux résidentiels municipaux d'eau potable

De nombreux documents utiles peuvent vous aider à exploiter votre réseau d'eau potable. Vous trouverez ci-après une liste de documents que les propriétaires et exploitants de réseaux résidentiels municipaux d'eau potable utilisent fréquemment. Pour accéder à ces documents en ligne, cliquez sur leur titre dans le tableau ci-dessous ou faites une recherche à l'aide de votre navigateur Web. Communiquez avec le ministère au 1-866-793-2588, ou encore à waterforms@ontario.ca si vous avez des questions ou besoin d'aide.



Pour plus de renseignements sur l'eau potable en Ontario, consultez le site www.ontario.ca/eaupotable

TITRE DE LA PUBLICATION	NUMÉRO DE PUBLICATION
Renseignements sur le profil du réseau d'eau potable	012-2149F
Avis de demande de services de laboratoire	012-2148F
Avis de résultats d'analyse insatisfaisants et de règlement des problèmes	012-4444F
Prendre soin de votre eau potable - Un guide destiné aux membres des conseils municipaux	Site Web
Marche à suivre pour désinfecter l'eau potable en Ontario	Site Web
Stratégies pour minimiser les trihalométhanes et les acides haloacétiques de sous-produits de désinfection	Site Web
Filtration Processes Technical Bulletin (en anglais seulement)	Site Web
Ultraviolet Disinfection Technical Bulletin (en anglais seulement)	Site Web
Guide de présentation d'une demande de modification du permis d'aménagement de station de production d'eau potable	Site Web
Guide sur l'accréditation des exploitants de réseaux d'eau potable et des analystes de la qualité de l'eau de réseaux d'eau potable	Site Web
Guide sur les exigences relatives à la formation des exploitants de réseaux d'eau potable	9802F
Échantillonnage et analyse du plomb dans les collectivités : échantillonnage normalisé ou réduit et admissibilité à l'exemption	Site Web
Liste des personnes-ressources du réseau d'eau potable	Site Web
L'eau potable en Ontario - Norme de gestion de la qualité - Guide de poche	Site Web
Procédure de désinfection des conduites principales	Site Web
Laboratoires autorisés	Site Web